

# A60 Series



## Marine Fire Dampers

Fully compatible with control systems.  
24 volt and 230 volt actuator options.  
Construction material options.

- Marine fire damper for HVAC systems on-board marine vessels
- MED certified for A60 fire performance
- USCG Approved
- SOLAS Compliant
- Lloyds Register Certified to IMO Fire Test Procedures

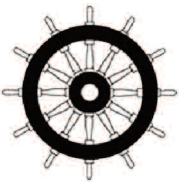

0038/20XX

# A60 Series

## Marine Fire Damper - Introduction



### Introduction

The BSB A60 multiblade Marine Fire Damper is designed for use on marine vessels to protect the integrity of fire rated bulkheads and decks. Each A60 damper is controlled by an electrical failsafe spring return actuator combined with a thermoelectric tripping device (thermal fuse) and volt free contacts for remote status indication.

The A60 damper can be used where the maximum system pressure is 2000 Pa and duct velocities do not exceed 20 m/s. The A60 Marine Fire Damper has been tested in accordance with EN1751 with case leakage conforming to classes A, B and C and closed blade leakage to class B.

The A-60 Marine Fire Damper is suitable for both vertical and horizontal applications, with airflow in either direction.

MED certified for A60 fire performance.

Conforms to Commission Implementing Regulation (EU) 2018/773.

### Models

**Type A60-S** Square/rectangular flange duct connections.

**Type A60-C** Circular flange duct connections.

### Size Ranges

#### Rectangular

100 mm W x 100mm H minimum

1000 mm W x 1000mm H maximum

Larger sizes are available as Multiple Assemblies for vertical installation only to a maximum size of 2080mm W x 1000mm H

#### Circular

100mm dia minimum. 1000mm dia maximum

Both the rectangular and circular model dimensions are available in 1mm increments.

### Casing Features

1.2mm galvanised steel flanged design case to BS EN 10346, (optional 2mm and 3mm thick casings available) and 316 grade stainless steel, both having a single penetration to accept coupling to the direct drive actuator.

Fully seam welded corners provide a rigid and air tight construction. Exposed welds are treated with protective corrosion resistant, environmental friendly water based paint for galvanised cases and passivated on stainless steel cases.

Pre-punched bolt holes are provided as standard to a universal pattern. Client's project specific hole pitch can be accommodated on request.

### Blade Features

A60 Fire Dampers are supplied with opposed blade operation. Blades are at 100mm pitches and manufactured from 0.7mm galvanised steel to BS EN 10346

and 316 grade stainless steel to BS EN 10088-2.

Both blade material options have interlocking engagement to provide low leakage and optimum fire resistance when closed.

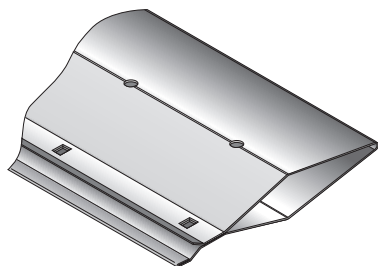

### Construction

#### Casings

Casings are supplied as standard in 1.2mm thick galvanised steel and are also available in 2mm and 3mm thick materials, with the option of 316L stainless steel type 1.4406/7.

#### Blades

Blades are formed double skin airfoil in shape, opposed blade action on a 100mm pitch that interlock when closed. They are manufactured in 0.7mm thick galvanised steel type DX 51D Z275 with the option of 316L stainless steel type 1.4406/7.

#### Gaskets

stainless steel peripheral gasketing 0.4mm 301 grade type 1.4310 fitted to both sides, top and bottom of damper internal case.

#### Linkage

The blade spindles are linked using a gear system, link arms and drive bars to give the opposed blade action. The link arms, drive strips and gears are made from 2.5mm galvanised steel type DX 51D Z275 and is fully enclosed outside the airstream.

#### Flanges

Pre-punched flange holes are provided as standard to a universal hole pattern. Bespoke configurations are available on request.

#### Other Components

All other components are manufactured from galvanised/zinc plated mild steel, with 316 stainless options available.

#### Blade shafts and bearings

The blades are each mounted on two 19mm diameter spindles.

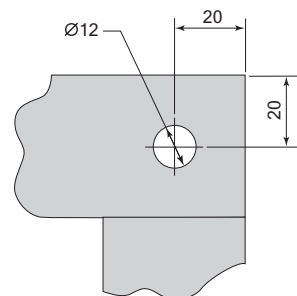
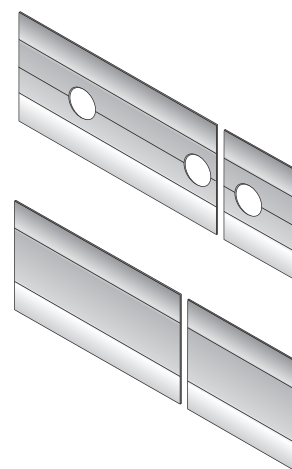

### Fire Testing

The BSB A-60 Marine Fire Damper has been subject to comprehensive fire testing for single and multiple sections.

The dampers were installed into a steel deck and bulkhead as specified in IMO Res.MSC.307(88)-2010 FTP Code, as amended.

### Testing, Approvals and Conformities

Tested and certificated for 60 minutes.

- Marine Equipment Directive (MED).
- Lloyds Register Approval to IMO Fire Test Procedures Code, Annex 1, Part 3, for Class AO, A15, A30 and A60 Division bulkheads and decks. In compliance with the appropriate Lloyds Register Rules and Regulations and with the international Convention for the Safety Of Life At Sea (SOLAS).
- USCG (United States Coast Guard).
- Corrosion Tested to BSEN 60068-2-52.
- Vibration Tested to BS EN 60068-2-6.
- EC Type Examination (Module B).
- EC (Module D).
- Certificate of Fire Approval.
- BRE Global Compliant to ISO 9001.

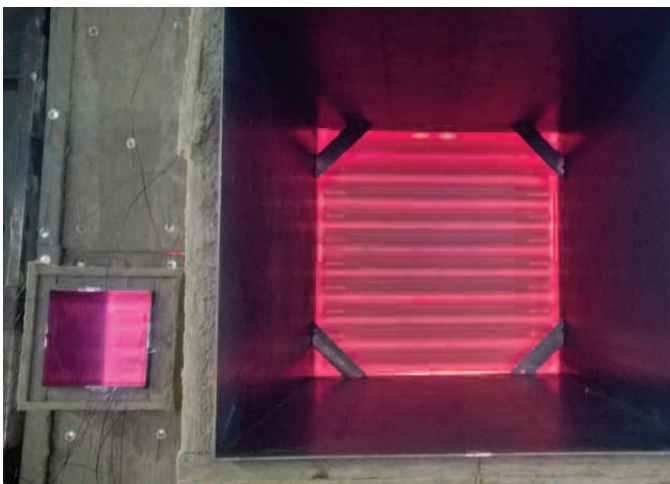

### Indication Control Units

This indication control unit is for illustrative purposes only.

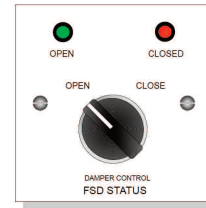

Shows open and closed status of 1 Fire/Smoke Damper.  
Control function to open/close damper.  
Includes link for fire alarm connection.  
Available in 24V AC/DC or 230V AC (depending on actuator voltage).

In accordance with 4.1.1.9 of SOLAS:2014, the fire damper should be capable of being closed from either side of the division and readily accessible.

BSB can supply indication control units that can indicate and operate dampers from either side of the fire separation barrier in accordance with the above regulation.

Please contact the BSB sales office for details.

### A60 Flange Gasket

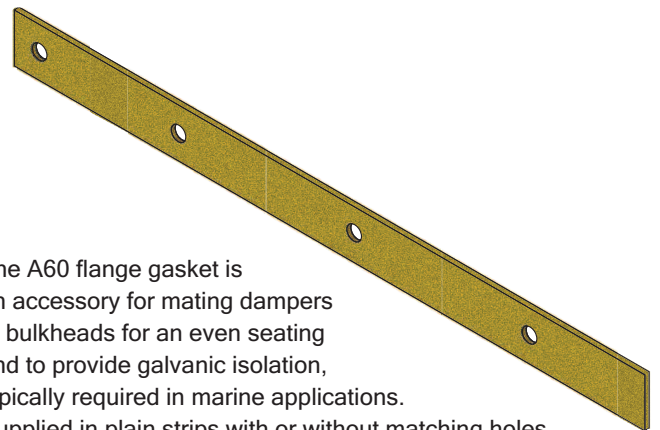

The A60 flange gasket is an accessory for mating dampers to bulkheads for an even seating and to provide galvanic isolation, typically required in marine applications. Supplied in plain strips with or without matching holes to suit the BSB damper flange.

Gasket for circular damper flange connections should be requested at time of placing an order, as the gasket will be provided between the damper case and square to round plate assembly at the factory.

Paint is not a reliable insulator especially under bolt heads, nuts and washers or metal edges. Paint is usually damaged on installation or subsequent movement.

Gasket may not always be a requirement but can provide assurance of a good mating seal.

#### Specification:

The BSB A60 gasket is a high quality 3mm thick non asbestos and non-ceramic fibre millboard for high temperature applications up to 1000°C. Supplied in strips 40mm wide x 3mm thick to suit dampers.

#### Key feature:

Low thermal conductivity.  
K value 0.12 W/mK.

# A60 Series

## Marine Fire Damper - Product Specification



### Product Specification

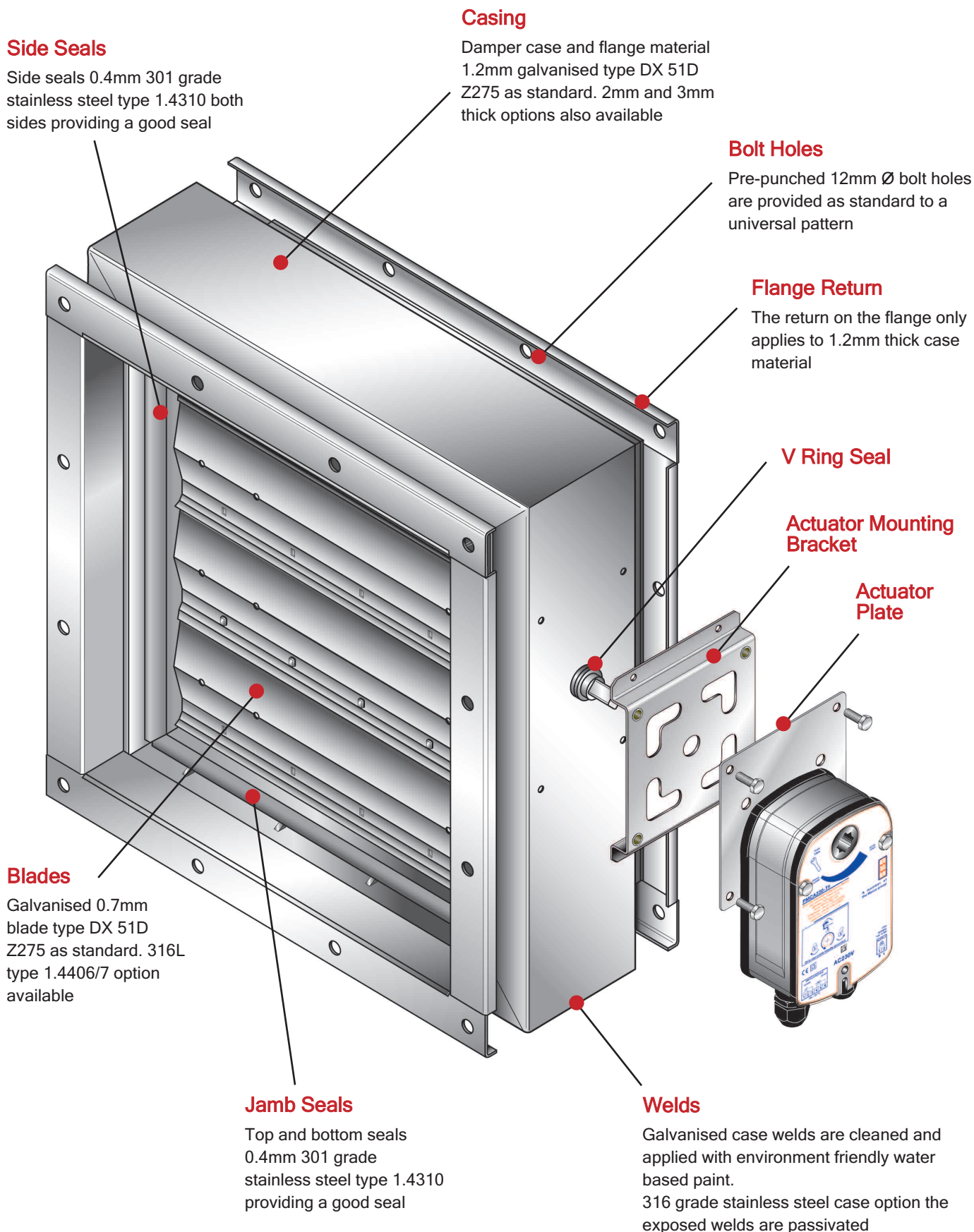

### Rectangular

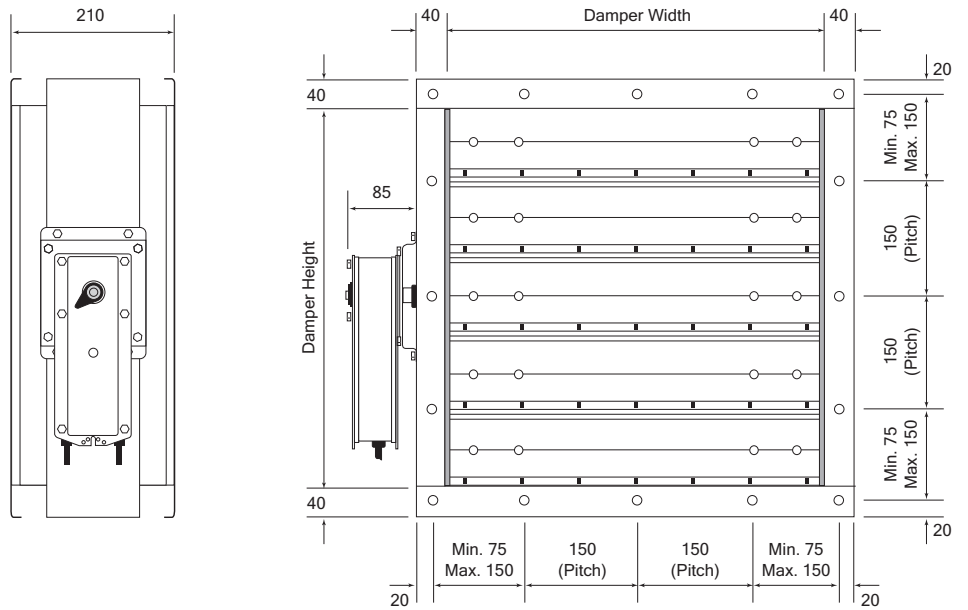

### Circular

**Circular Damper Fixing Hole Detail**  
 Number of holes equally spaced on PCD

Damper Dia.	Hole Dia.	No. of Holes
100 - 250	7.0	4 off
251 - 500	10.0	8 off
501 - 750	12.0	12 off
751 - 1000	12.0	16 off

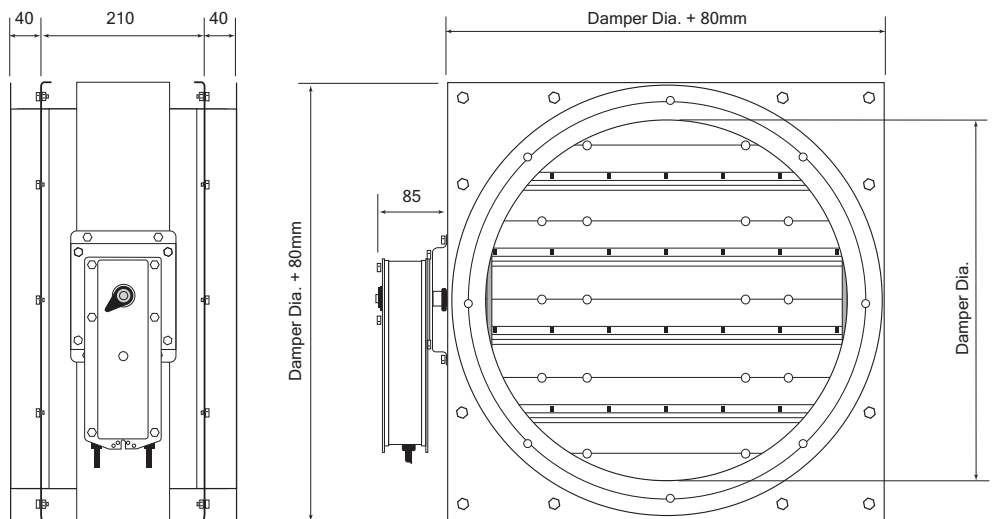

### Multiple Sections

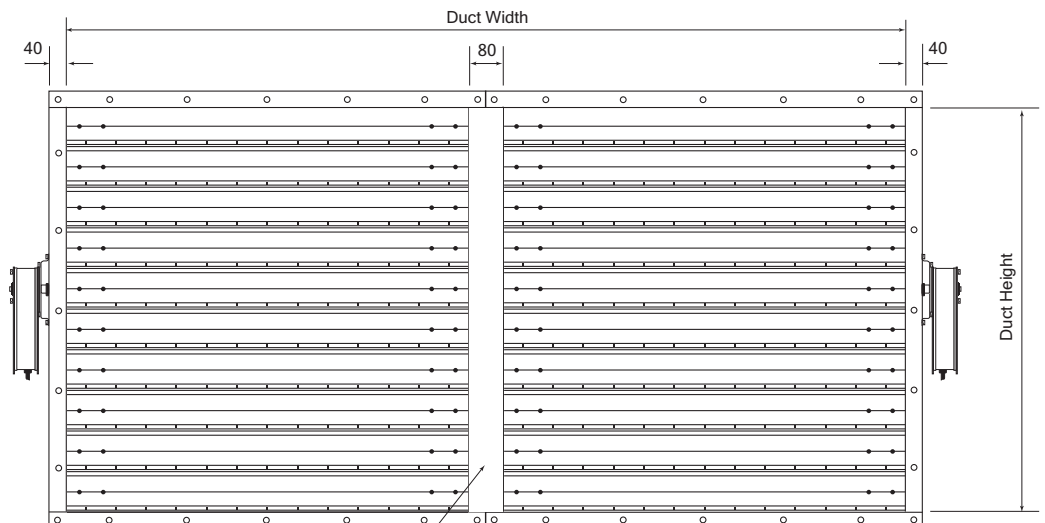

1.2MM Joining Strips with pre-punched 5mm holes for site assembly. One strip per side.

# A60 Series

## Marine Fire Damper - Electrical Actuator Specification



### Models

Two actuator models are available in 24 volt and 230 volt options. For dampers between 100mm and 300mm square, rectangular/diameter the PMCA24-TF (24 volt AC/DC) or PMCA230-TF (230 volt AC) actuator is supplied. Dampers larger than 300mm square rectangular/diameter to our largest manufactured single section size, will be supplied with the PM24-TF (24 volt AC/DC) or the PM230-TF (230 volt AC) actuator.

### Operation

A60 series dampers are supplied with automatic spring return failsafe electrical actuators with thermoelectric tripping device (thermal fuse) for attaching to the adjacent ductwork.

### Thermal Fuse

The thermoelectric tripping device is fitted with a green LED indication light, providing a quick visual check that the actuator is receiving power and that the thermal fuse is intact. Also included is a manual toggle test switch for periodic testing of the damper.

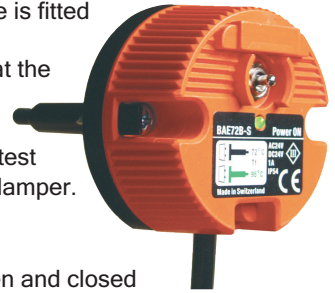

### Status Indication

Volt free contacts for damper open and closed remote indication are also provided.

### BSB PM24 -TF / BSB PM230 -TF

FOR A60 MARINE FIRE DAMPER SIZES ABOVE 300MM IN WIDTH OR HEIGHT

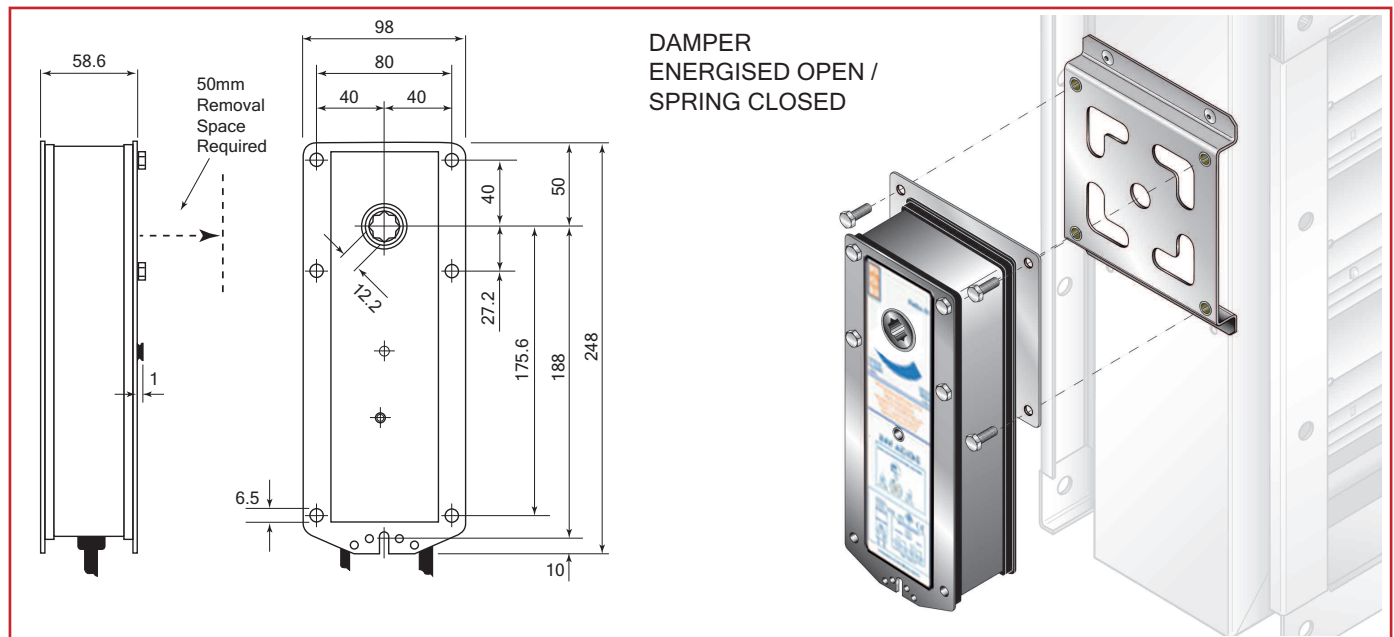

### BSB PMCA24 -TF / BSB PMCA230 -TF

FOR A60 MARINE FIRE DAMPER SIZES UP TO 300MM X 300MM

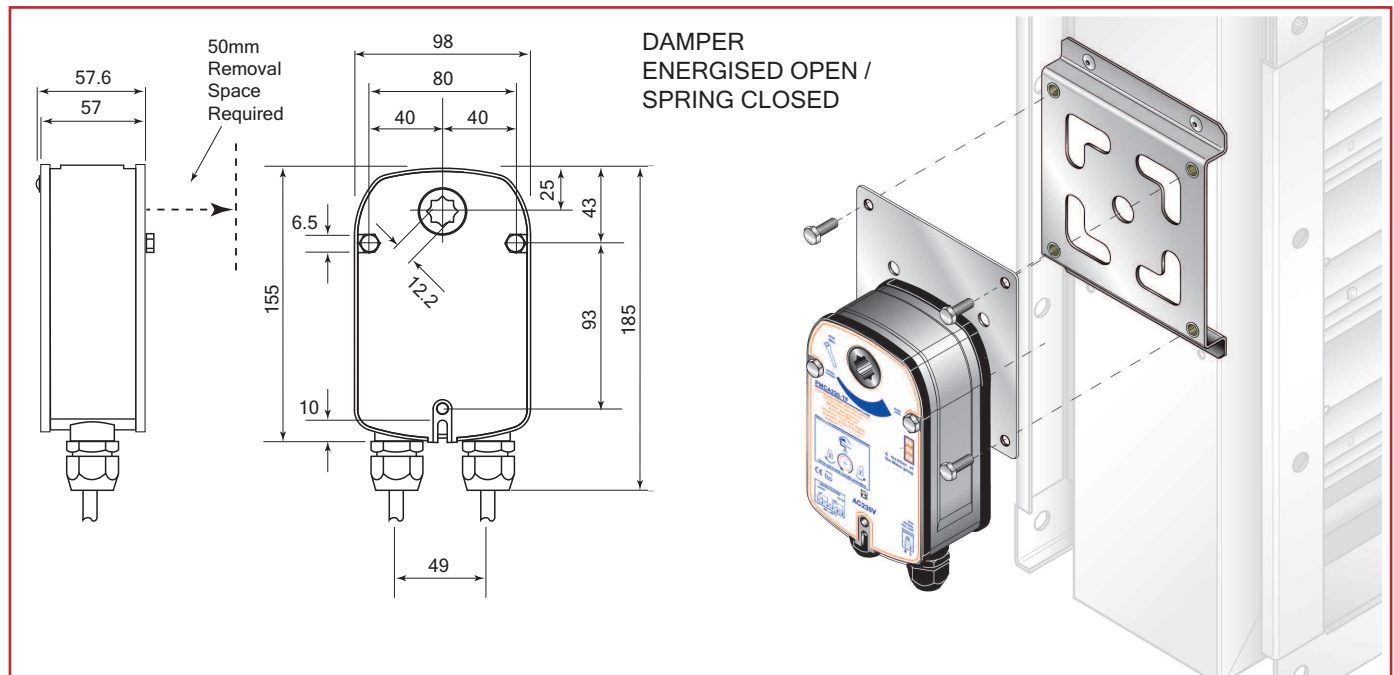

## Marine Fire Damper - Electrical Actuator Specification

### BSB PM24 -TF

### BSB PM230 -TF

### BSB PMCA24 -TF

### BSB PMCA230 -TF

#### Electrical data

Nominal voltage	24 V AC, 50/60 Hz / 24V DC	230 V AC, 50/60 Hz	24 V AC, 50/60 Hz / 24V DC	230 V AC, 50/60 Hz
Nominal voltage range	AC 19.2...28.8V / DC 21.6...28.8V	AC 196...264V	AC 19.2...28.8V / DC 21.6...28.8V	AC 196...264V
Power consumption motoring	10 W @ nominal torque	12 W @ nominal torque	5 W @ nominal torque	6 W @ nominal torque
Holding	2 W	4 W	2.5 W	3 W
For wire sizing	12.5 VA / I <sub>max</sub> . 8.3 A @ 5 ms	14 VA	7 VA / I <sub>max</sub> . 5.8 A @ 5 ms	7 VA / I <sub>max</sub> . 150mA @ 10 ms
Auxiliary switch	2 x 1 SPDT	2 x 1 SPDT	2 x SPDT	2 x SPDT
Contact rating (contacts gold plate on silver)	1 mA ... 6 A (3 A) DC 5 V ... AC 250 V	1 mA ... 6 A (3 A) DC 5 V ... AC 250 V	1 mA ... 3 A (0.5) DC 5 V ... AC 250 V	1 mA ... 3 A (0.5) DC 5 V ... AC 250 V
Switching points	5° / 85°	5° / 85°	5° / 30°	5° / 30°
Thermal fuse	72°C	72°C	72°C	72°C
Supply cable (halogen free)	1.0 m, 2 x 0.75 mm <sup>2</sup>	1.0 m, 2 x 0.75 mm <sup>2</sup>	1.0 m, 2 x 0.75 mm <sup>2</sup>	1.0 m, 2 x 0.75 mm <sup>2</sup>
Signal cable (halogen free)	1.0 m, 6 x 0.75 mm <sup>2</sup>	1.0 m, 6 x 0.75 mm <sup>2</sup>	1.0 m, 6 x 0.75 mm <sup>2</sup>	1.0 m, 6 x 0.75 mm <sup>2</sup>

#### Functional data

Running time motor	< 60 s	< 60 s	< 60 s	< 60 s
Spring-return (at 20°C)	< 30 s	< 30 s	< 30 s	< 30 s
Sound power level motor	Max. 45 dB (A)	Max. 45 dB (A)	Max. 45 dB (A)	Max. 45 dB (A)
Spring-return	~62 dB (A)	~62 dB (A)	~62 dB (A)	~62 dB (A)
Position indication	Mechanical with pointer	Mechanical with pointer	Mechanical with pointer	Mechanical with pointer
Service life	Min. 10,000 full cycles @ 15Nm followed by 50 full cycles @ 20Nm	Min. 10,000 full cycles @ 15Nm followed by 50 full cycles @ 20Nm	Min. 60,000 safety positions	Min. 60,000 safety positions

#### Safety

Protection class	III Safety extra low voltage	II totally insulated	III Safety extra low voltage	II totally insulated
Degree of protection (including Thermal Fuse)	IP54 in all mounting positions	IP54 in all mounting positions	IP54 in all mounting positions	IP54 in all mounting positions
EMC	CE according to 2014/30/EU	CE according to 2014/30/EU	CE according to 2014/30/EU	CE according to 2014/30/EU
Ambient temperature range	normal duty -30°C to +50°C	normal duty -30°C to +50°C	normal duty -30°C to +50°C	normal duty -30°C to +50°C
Non-operating temperature	-40°C ... +50°C	-40°C ... +50°C	-40°C ... +50°C	-40°C ... +50°C
Ambient humidity range	95% r.H., non-condensing (EN60730-1)	95% r.H., non-condensing (EN60730-1)	95% r.H., non-condensing (EN60730-1)	95% r.H., non-condensing (EN60730-1)
Maintenance	Maintenance-free	Maintenance-free	Maintenance-free	Maintenance-free

#### Weight

Weight	Approx. 3.1kg	Approx. 3.5kg	Approx. 1.6kg	Approx. 1.73kg
--------	---------------	---------------	---------------	----------------

### BSB PM24 -TF / BSB PM230 -TF FOR DAMPER SIZES ABOVE 300MM IN WIDTH OR HEIGHT DAMPER ENERGISED OPEN / SPRING CLOSED

- Wiring diagram shows switch positions based on no power to actuator
- Power on - Damper in non alarm position
- Power off - Damper or Thermal Fuse activation, Damper in fail safe position
- External remote blade position via auxiliary contacts
- LSF insulated cables
- IP54 rated
- Thermal fuse rated at 72°C
- Unused cores should be isolated
- Connecting cables need to be protected from sharp edges

For damper closed indication use terminals 1 & 2  
For damper open indication use terminals 4 & 6  
Terminals 1 & 4 can be linked where required as an option

#### BSB PM24 -TF

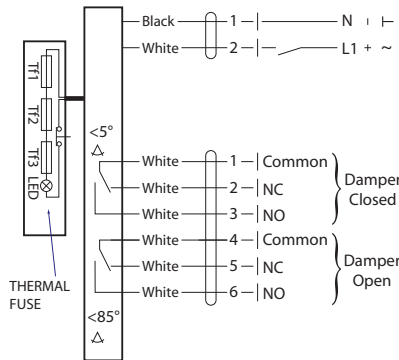

**24V AC/DC:**  
Connect via safety isolation transformer

#### BSB PM230 -TF

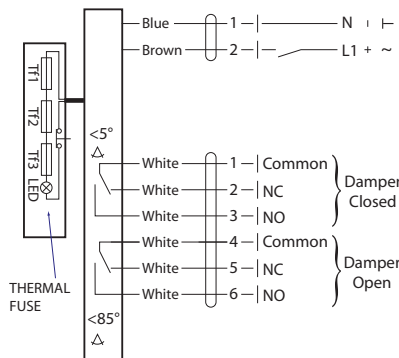

**230V AC/DC:**  
For disconnection from mains power supply, a separate device must be incorporated in the fixed wiring with at least 3mm contact gap in all poles.

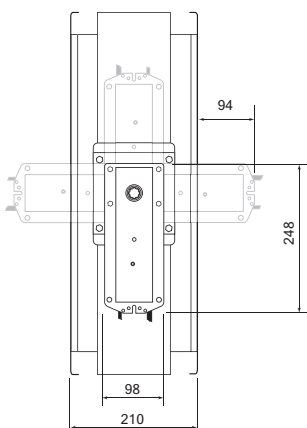

#### Positioning

The actuator can be fitted in one of four positions for flexibility of installation. Actuators are supplied factory fitted and tested.

### BSB PMCA24 -TF / BSB PMCA230 -TF FOR DAMPER SIZES UP TO 300MM IN WIDTH AND HEIGHT DAMPER ENERGISED OPEN / SPRING CLOSED

- Wiring diagram shows switch positions based on no power to actuator
- Power on - Damper in non alarm position
- Power off - Damper or Thermal Fuse activation, Damper in fail safe position
- External remote blade position via auxiliary contacts
- LSF insulated cables
- IP54 rated
- Thermal fuse rated at 72°C
- Unused cores should be isolated
- Connecting cables need to be protected from sharp edges

For damper closed indication use terminals 1 & 2  
For damper open indication use terminals 4 & 6  
Terminals 1 & 4 can be linked where required as an option

#### BSB PMCA24 -TF

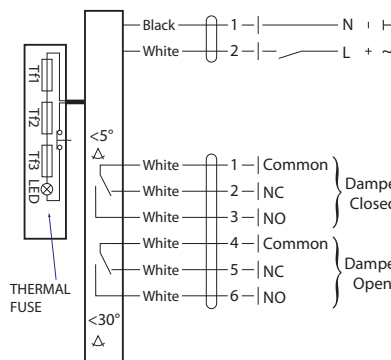

**24V AC/DC:**  
Connect via safety isolation transformer

#### BSB PMCA230 -TF

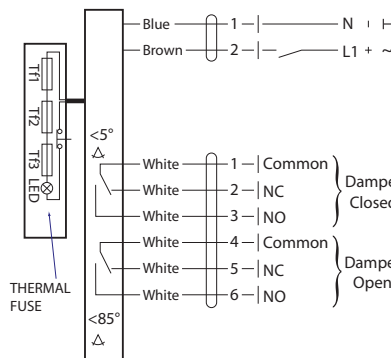

**230V AC/DC:**  
For disconnection from mains power supply, a separate device must be incorporated in the fixed wiring with at least 3mm contact gap in all poles.

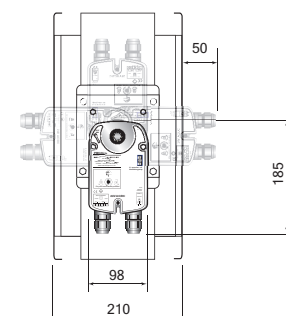

#### Positioning

The actuator can be fitted in one of four positions for flexibility of installation. Actuators are supplied factory fitted and tested.



### Bulkhead Installation

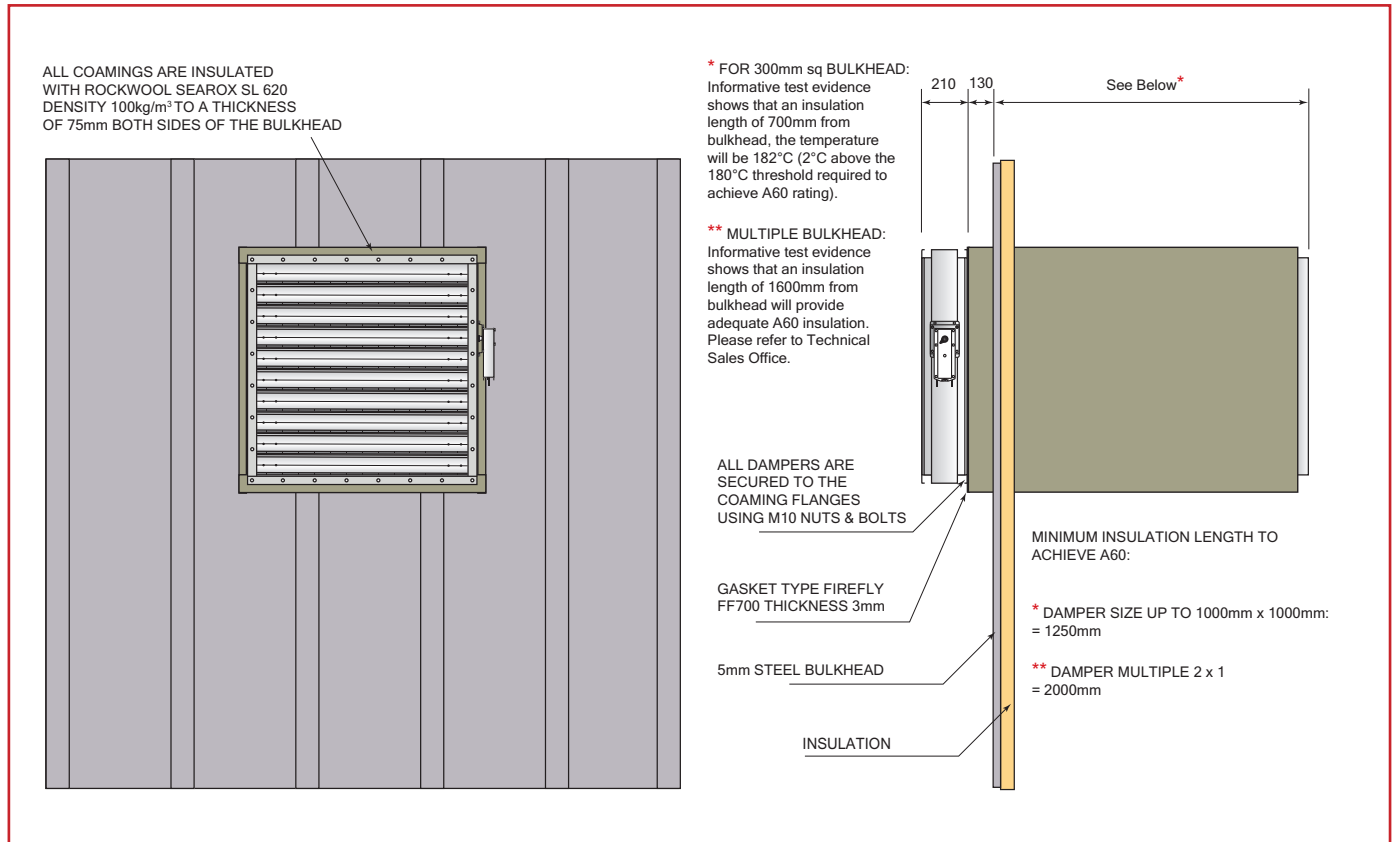

### Deck Installation

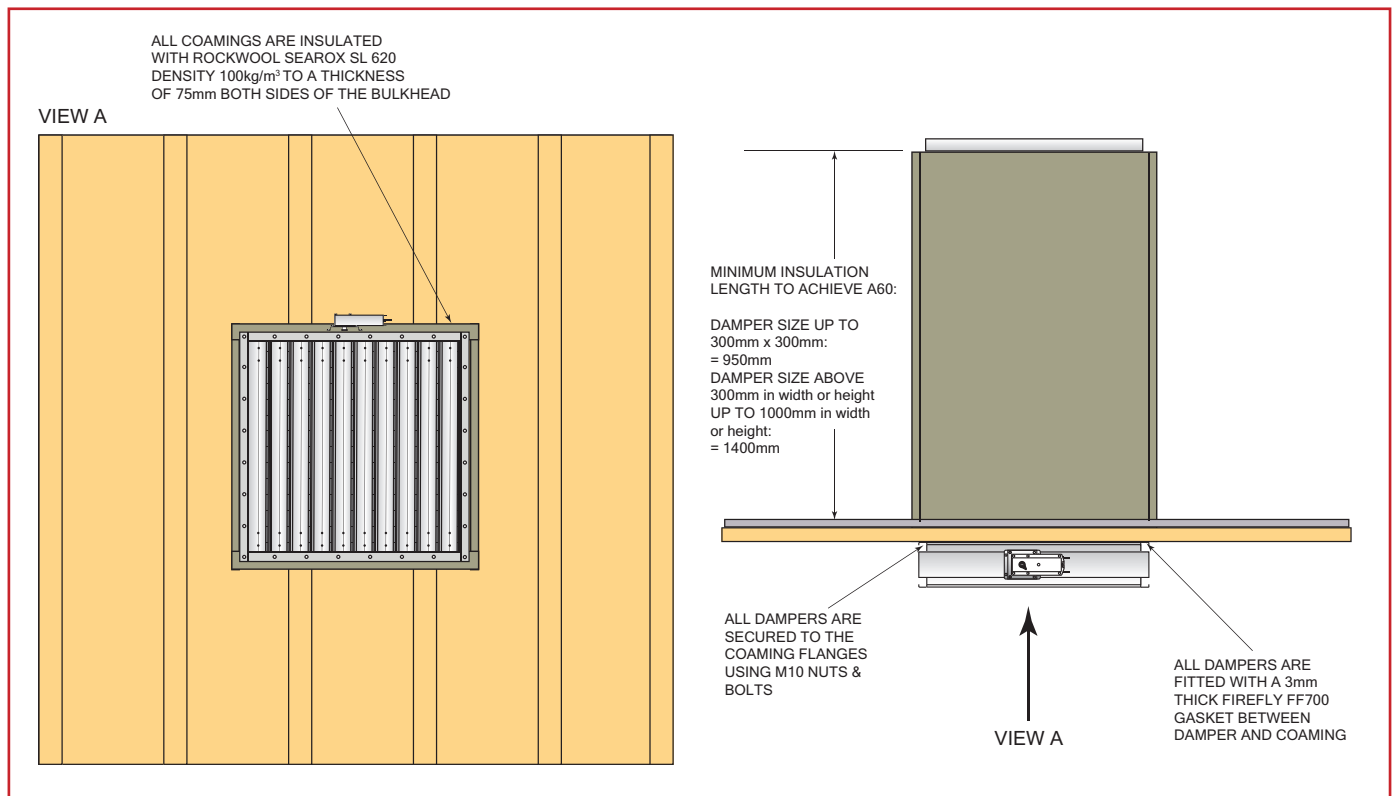

The bulkhead and deck to be in accordance with FTP code 2010 Figure 12. Insulation material and thickness for the bulkhead and deck should be in accordance with the manufacturers instruction. The length specified is required to achieve A60 classification. For AO classification, insulation is not a requirement.

# A60 Series

## Marine Fire Damper - Performance Data



### Performance Data

**Pressure Drop** BSRIA Report 15633/1 BS EN 1751  
Dynamic performance on a 500mm W x 600mm H damper

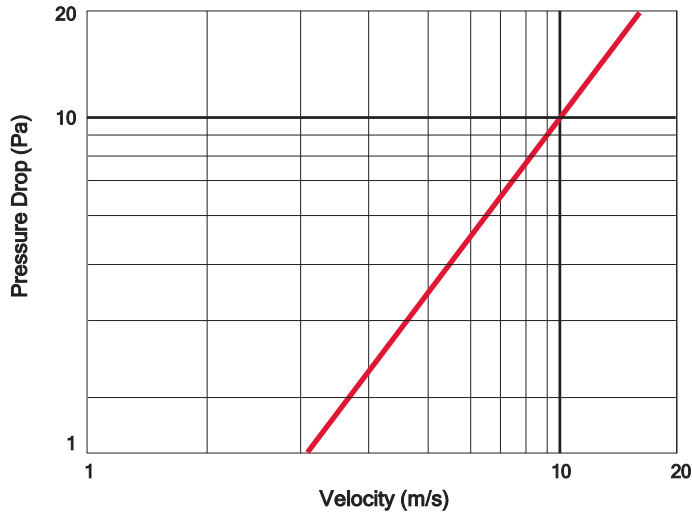

### Ambient Case Leakage

An A60 damper was tested and was found to meet Class 'C' Classification BS EN 1751. With leakage being recorded at less than 0.1l/s/m<sup>2</sup> at 2000 Pa

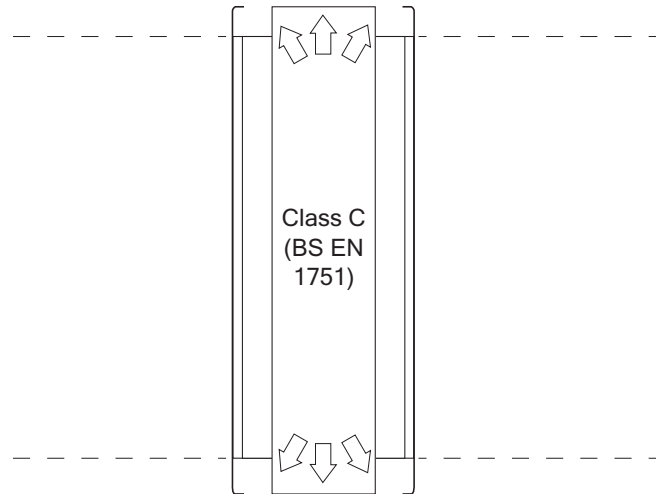

**Ambient Blade Leakage**  
for a 500mm square A60 Damper

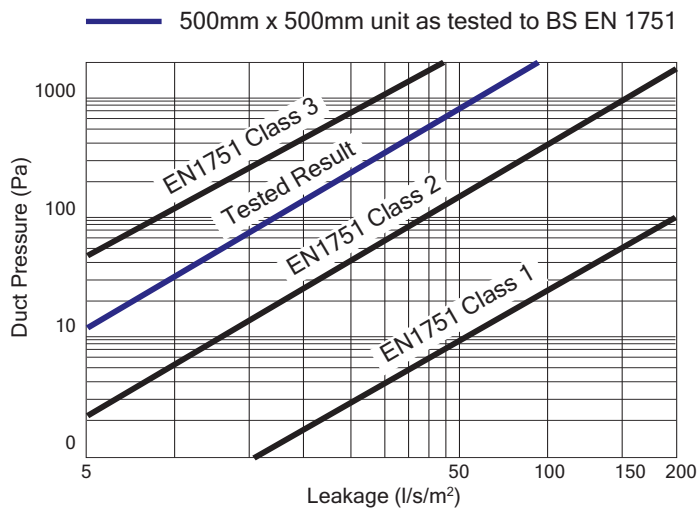

### Maintenance Notes

A60 Series dampers are designed for normal dry filtered air systems. A programme of planned inspections should be carried out to include full operational checks, correct interface with, and function of, any control systems, cleaning and light lubrication.

As a guide, this should take place on a maximum of six months intervals.

Reference should be made to BS 9999 for more information. Records of damper installation, location and maintenance log shall be kept on board the vessel. These inspection and maintenance programmes may need to be repeated more regularly if the dampers are exposed to inclement/dusty conditions or fresh air intakes. The frequency of such checks should be developed based on site experience.

### Recycling

BSB recognises the need to preserve resources and reduce emissions and are actively working towards and introducing more efficient ways of manufacturing.

BSB supports and recommends that good waste management practice be adopted on all new and refurbishment projects, regardless of size. This not only reduces emissions, preserves raw materials and saves energy, but also reduces costs long term.

BSB are proud that their dampers are 95% minimum recyclable.

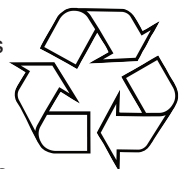

**Weight Charts** Values are shown in kg and are approximate.

**Rectangular Model A60 with 1.2mm galvanised blades and casings** (including actuator)  
100mm to 1000mm max. width and 100mm to 1000mm max. height.

Damper Height (mm)	Damper width (mm)									
	100	200	300	400	500	600	700	800	900	1000
100	6.0	7.5	8.5	11.5	12.5	14.0	15.0	16.5	17.5	18.5
200	8.0	9.0	10.5	13.5	14.5	16.0	17.5	18.5	20.0	21.5
300	9.5	11.0	12.5	15.5	17.0	18.0	19.5	21.0	22.5	24.0
400	12.5	14.0	15.5	17.0	19.0	20.5	22.0	23.5	25.0	27.0
500	14.0	15.5	17.5	19.0	21.0	22.5	24.5	26.0	28.0	29.5
600	15.5	17.5	19.0	21.0	23.0	24.5	26.5	28.5	30.5	32.0
700	17.0	19.0	21.0	23.0	25.0	27.0	29.0	31.0	33.0	35.0
800	18.5	20.5	22.5	25.0	27.0	29.0	31.0	33.5	35.5	37.5
900	20.0	22.5	24.5	27.0	29.0	31.0	33.5	35.5	38.0	40.0
1000	21.5	24.0	26.5	28.5	31.0	33.5	36.0	38.0	40.5	43.0

**Circular Flange Model A60 with 1.2mm galvanised blades and casings** (including actuator)

Diameter	Weight (kg)
100	8.0
200	12.0
300	17.0
400	23.0
500	28.5
600	34.0
700	40.0
800	46.0
900	53.0
1000	60.0

**Rectangular Model A60 with 2mm galvanised blades and casings** (including actuator)  
100mm to 1000mm max. width and 100mm to 1000mm max. height.

Damper Height (mm)	Damper width (mm)									
	100	200	300	400	500	600	700	800	900	1000
100	6.5	8.5	10.0	13.0	14.5	16.5	18.0	19.5	21.0	22.5
200	8.5	10.5	12.0	15.5	17.0	19.0	20.5	22.5	24.0	26.0
300	10.5	12.5	14.5	18.0	19.5	21.5	23.5	25.0	27.0	29.0
400	14.0	16.0	18.0	20.0	22.0	24.0	26.0	28.0	30.0	32.0
500	16.0	18.0	20.5	22.5	24.5	26.5	29.0	31.0	33.0	35.0
600	18.0	20.0	22.5	24.5	27.0	29.0	31.5	33.5	36.0	38.0
700	20.0	22.0	24.5	27.0	29.5	32.0	34.0	36.5	39.0	41.5
800	22.0	24.5	27.0	29.5	32.0	34.5	37.0	39.5	42.0	44.5
900	23.5	26.5	29.0	31.5	34.5	37.0	39.5	42.0	45.0	47.5
1000	25.5	28.5	31.0	34.0	36.5	39.5	42.0	45.0	48.0	50.5

**Circular Flange Model A60 with 2mm galvanised blades and casings** (including actuator)

Diameter	Weight (kg)
100	8.5
200	14.0
300	20.0
400	27.5
500	34.0
600	41.0
700	48.0
800	56.0
900	64.0
1000	72.0

**Rectangular Model A60 with 3mm galvanised blades and casings** (including actuator)  
100mm to 1000mm max. width and 100mm to 1000mm max. height.

Damper Height (mm)	Damper width (mm)									
	100	200	300	400	500	600	700	800	900	1000
100	8.0	10.0	12.0	16.0	18.0	20.0	22.0	24.5	26.5	28.5
200	10.5	12.5	15.0	18.5	21.0	23.0	25.5	27.5	30.0	32.0
300	13.0	15.0	17.5	21.5	24.0	26.0	28.5	31.0	33.5	35.5
400	17.0	19.5	22.0	24.5	27.0	29.5	32.0	34.5	37.0	39.5
500	19.5	22.0	24.5	27.0	30.0	32.5	35.0	37.5	40.5	43.0
600	21.5	24.5	27.0	30.0	32.5	35.5	38.0	41.0	43.5	46.5
700	24.0	27.0	30.0	33.0	32.5	38.5	41.5	44.5	47.0	50.0
800	26.5	29.5	32.5	35.5	38.5	41.5	44.5	47.5	50.5	53.5
900	29.0	32.0	35.0	38.5	41.5	44.5	48.0	51.0	54.0	57.0
1000	31.5	34.5	38.0	41.0	44.5	47.5	51.0	54.5	57.5	61.0

**Circular Flange Model A60 with 3mm galvanised blades and casings** (including actuator)

Diameter	Weight (kg)
100	10.5
200	18.0
300	25.5
400	34.5
500	43.0
600	52.0
700	61.0
800	71.0
900	81.5
1000	92.0

# A60 Series

## Marine Fire Damper - Ordering Codes

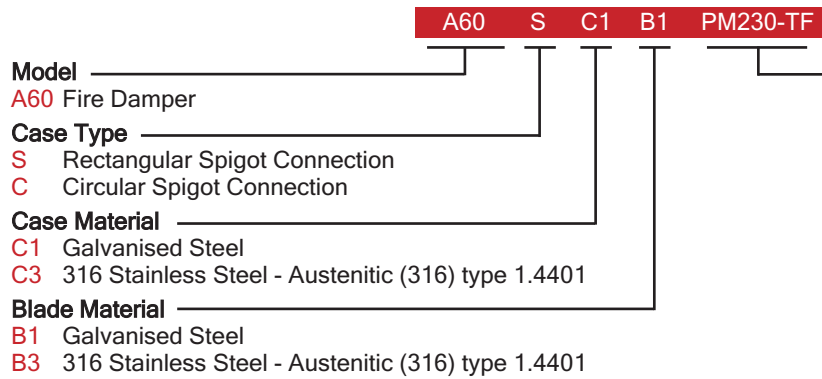

### Other Air, Fire and Smoke Control Products in the BSB Range:



For full details of the complete BSB Product Range, please refer to our individual product brochures, sales office or website.



### BSB Engineering Services Limited

Unit 56, Trinity Trade Centre, Mill Way, Sittingbourne, Kent ME10 2PD, UK • Tel: +44 (0)1795 422609

For purchase orders and order related enquiries, please email: [orders@bsb-dampers.co.uk](mailto:orders@bsb-dampers.co.uk)

For pricing, technical and general enquiries, please email: [enquiries@bsb-dampers.co.uk](mailto:enquiries@bsb-dampers.co.uk)

Website: [www.bsb-dampers.co.uk](http://www.bsb-dampers.co.uk) • A member of the Maico group

BSB Engineering Services Ltd. reserves the right to modify or withdraw any specification without prior notice that may result from continuous product development. The information contained within this brochure is correct at the time of going to press. (A60-08-2019)

