



Installation Instruction & Reference Guide



IMPORTANT SAFETY INSTRUCTIONS:

Read instructions completely before beginning installation.
Test the system before putting the boat in the water. Keep this manual on your boat.

Congratulations, you are the owner of Bennett's Premier XPT System — the most prestigious trimming system in the world. Bennett Marine is recognized worldwide for durability, strength, and unparalleled customer satisfaction.

How to Use Your Premier XPT Trim Tab System

Getting and Staying Trimmed

Your vessel will "break over" or plane at a particular speed. This speed is determined by weight distribution, water conditions, etc. Your XPT trim tabs enable you to plane at lower speeds. By depressing the helm control in the "Bow Down" position, your trim tabs move down. This will raise your stern and lower your bow, getting you up on plane faster and increasing your speed.

Your Vessel's Optimum Attitude

Determine your optimum attitude by conducting this test: Get out and run at full speed in calm water. Notice the bow in relation to the horizon. This should be your best running attitude. You can use your trim tabs to recreate this "optimum attitude," correcting for changes in weight distribution, speed and water conditions.

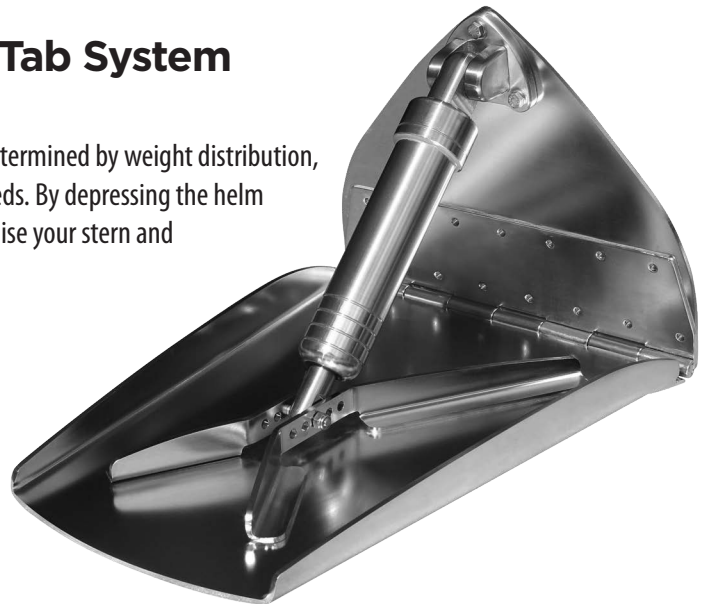

Getting Used to the "Feel" of Your Tabs

When learning to use the XPT, begin by pressing the helm control in half-second bursts, allowing time between corrections for gradual trimming. Do not over-trim. An over-trimmed vessel will "plow" or "bow-steer." If you over-trim, simply press "BOW UP" and the bow will rise.

Trimming From a Bridge or Tower

When steering from a bridge or tower, a good trimming method is to watch the bow spray, stern wake, or the rooster tail. An untrimmed vessel will produce spray farther aft of the bow and it will produce a larger wake. When trimmed, the bow spray is farther forward, the wake is reduced, and the rooster tail is smaller and farther behind the boat. You'll also notice that the engine RPM may increase when the boat is properly trimmed.

Running in Rough Water

When running in a chop, press "BOW DOWN". This will bring the "V" of the hull in contact with the waves rather than having the waves pound the flatter portion of the hull and your passengers. In a following sea or when running an inlet, the trim tabs should be fully retracted for maximum rudder response.

Correcting for a "Listing" Condition

The XPT trim tabs may be operated individually so that you can correct for a "listing" condition. Your control is designed so that you can use it "intuitively." Do not think about what the trim tabs are doing, just concentrate on your bow. If the port bow is high, push the port side "Bow Down" direction. If the starboard bow is high, push the starboard side "Bow Down" direction until the "listing" condition is corrected.

Safety Precautions

- Do not over-trim, particularly at high speeds as the bow may dig in and wave action may cause the vessel to veer.
- While underway, do not move one trim tab significantly farther down than the other as undesirable listing could occur.
- For best maneuverability, trim tabs should be fully retracted in a following sea, or when running an inlet.
- Improper use of trim tabs can cause an unexpected attitude change of vessel, which could lead to an unsafe condition.

The XPT System will have a significant effect on the operation and versatility of the vessel. The best learning method is to spend time getting familiar with your vessel's reaction to trim tabs. Always operate your vessel with safety first in mind.

Installation Instructions for Dual Acting XPT System

READ THIS FIRST BEFORE BEGINNING INSTALLATION

IMPORTANT FOR ACTUATOR INSTALLATION ON ALL BOATS

Actuators must be installed perpendicular to the trim tabs and parallel to each other. Stainless steel is not flexible. Measurements have to be precise.

BE CAREFUL NOT TO ROTATE THE ACTUATOR SHAFT — ROTATING THE SHAFT WILL DAMAGE THE INTERNAL SENSOR.

IMPORTANT: FOR BOATS KEPT IN SEAWATER

THIS SYSTEM MUST BE PROTECTED FROM ELECTROLYSIS AND GALVANIC CORROSION — THIS DAMAGE IS NOT COVERED UNDER WARRANTY

To provide protection from electrolytic corrosion a zinc anode must be applied to each tab. In the case of tabs installed on the boat as original equipment by the builder, a bonding system may be utilized for your particular model. The XPT system top portion of the actuator and the actuator shaft are electrically isolated from each other. Therefore the trim plane and the upper part of the actuator must be individually protected or integrated into a bonding system.

NOTE: NOT INTENDED FOR RACING BOATS

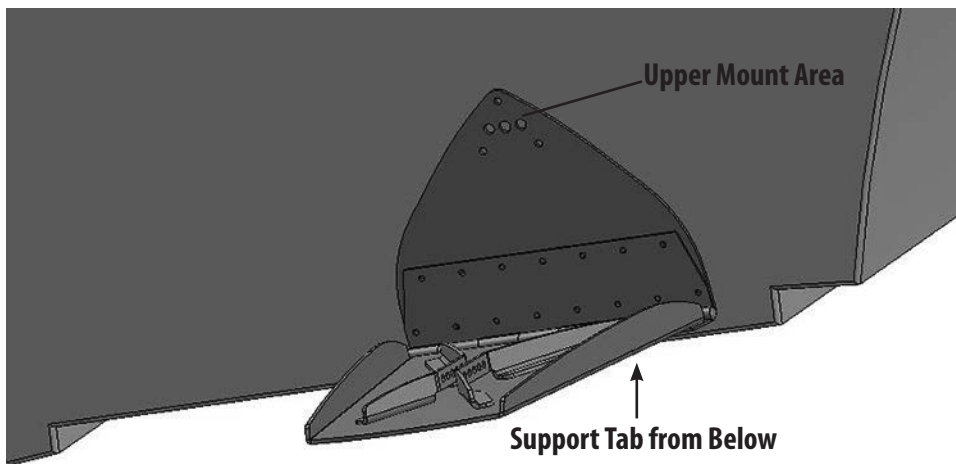

Figure 1

Step 1: Positioning Tabs

Position the backing plate against the transom and, while supporting the trim plane from below, check to see that the upper mounts of the hydraulic actuators do not center on an inside obstruction. If they do, reposition tabs slightly outboard. The further outboard the tabs are mounted, the greater the lateral (side-to-side) control. Position tabs 3"-4" (8-10 cm) from the chine and run towards the centerline of the boat. (See Figure 1)

Step 2: Mark and Drill Holes

Continuing to support the tab, use the backing plate as a template to mark all the hole locations. If the transom is curved, a shim must be made of a suitable material to provide a flat mounting surface.

Drill the holes on the trim plane mounting plate. All the holes should be drilled at the same time. Drill the marked 11/32" (9mm) mounting holes for each actuator. Drill the 3/4" (19mm) hole in the transom for the sensor wire. Drill the 1/2" (12mm) holes for the pipe nipples. And drill the appropriately sized holes for the mounting plate based on the stainless steel fasteners chosen for install.

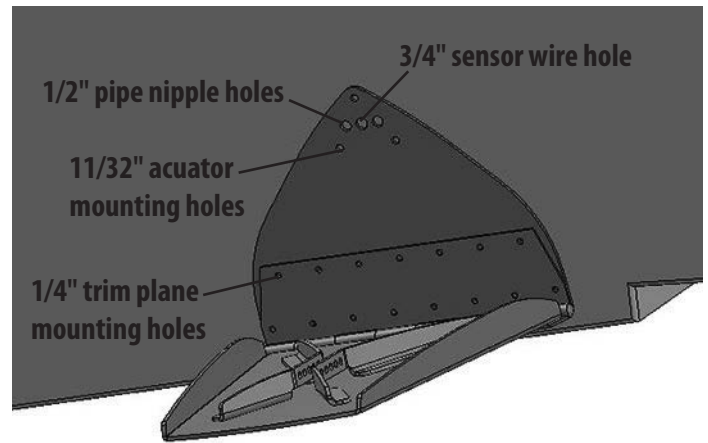

Figure 2

Apply sealant on the back of the backing plate and put plate on the transom.

Dip the selected stainless steel fasteners screws in marine epoxy before running in. Snug screws down to secure trim tab to transom.

IMPORTANT INSTALLATION NOTICE: MAKE SURE ACTUATOR UPPER MOUNTS FACE THE CORRECT WAY

The upper mount is able to pivot through 180 degrees but there is only one correct way to install it. The pointed end of the upper mount must face up as shown here.

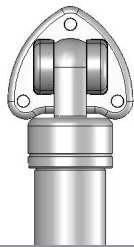

Step 3: Mounting the Actuators to the Transom

Carefully remove hex plugs from the fluid holes in the actuator upper mounts. **The actuators contain a large amount of automatic transmission fluid.**

Apply Teflon tape on male threads of pipe nipples and tighten into the actuator upper mounts. (See Figure 3)

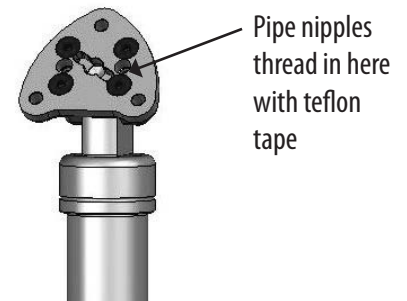

Figure 3

Before pushing the pipe nipples and sensor plugs through the holes in the transom, cover the ends with masking tape to prevent damage or debris from entering the system.

Carefully insert sensor wire through center hole. Pull all slack sensor wire into the boat. Apply waterproof sealant on surface of the upper hinge mount, around pipe nipples and screw holes. Apply sealant to the backing plate where the actuator upper mount will attach. Insert pipe nipples through transom and secure actuator upper mounts to transom with 5/16" (8mm) fasteners. Actuators should be through-bolted to transom. Do not tighten bolts.

Step 4: Attach Actuator

Continue supporting the trim tab assembly from below in the full retracted position.

Attach actuator to the center hole of the "X" bracket on the trim plane using 5/16 -18 hex head screw and nylon stop nut. (See Figure 4)

Step 5: Tighten the Bolts

Tighten the three upper mount bolts run through the transom in Step 3.

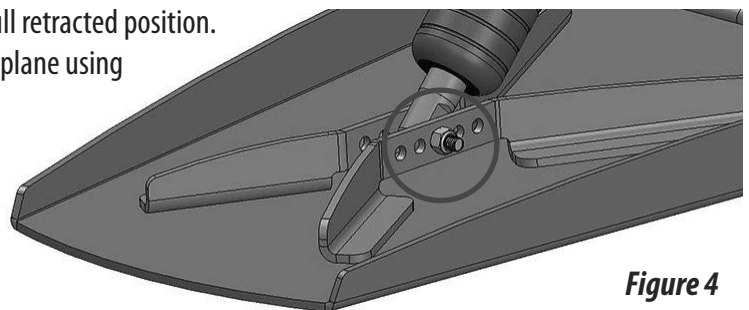

Figure 4

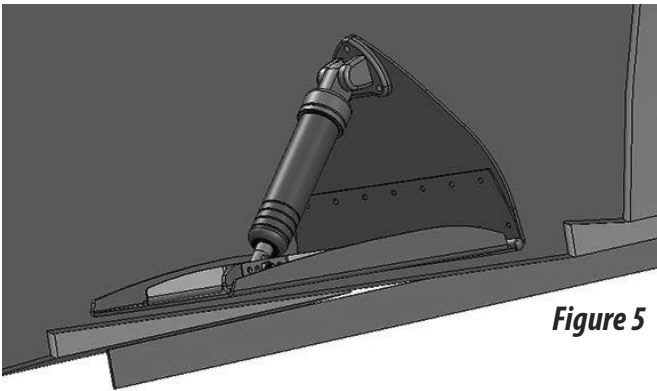

Figure 5

Step 6: Adjust Negative Angle

Use a straightedge and adjust the negative angle to your specification. (See Figure 5)

Note for Dual Actuator Systems

For each side of the boat, only one actuator per tab will have a sensor — one for the port side and one for the starboard side. It does not matter which of the dual actuators has the sensor (inboard or outboard). (See Figure 6)

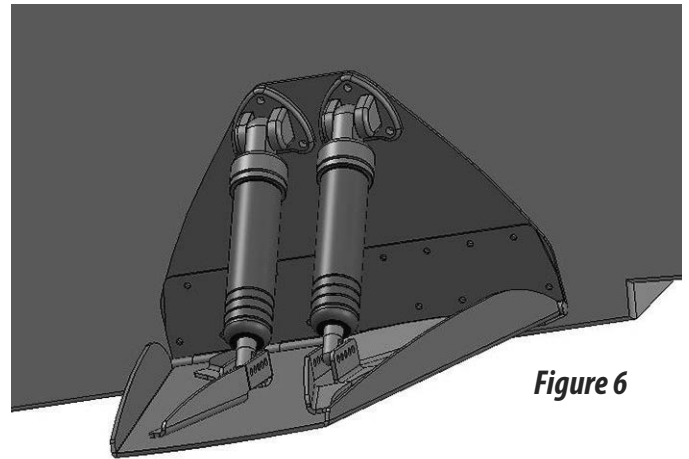

Figure 6

Step 7: Filling the Oildyne Hydraulic Power Unit (Pump)

Remove the yellow cap from the reservoir and fill using **any type of automatic transmission fluid (ATF)**.

Step 8: Mounting the Oildyne Hydraulic Power Unit

Choose a dry and convenient location to install the Oildyne Hydraulic Power Unit. **Important: The Oildyne Hydraulic Power Unit must be installed in a dry enough location to avoid drenching .**

Step 9: Attaching Fittings

Inside the transom, remove the protective tape from the pipe nipples. Check that the pipe nipples are clean and clear. Then apply Teflon tape on male threads of pipe nipples and tighten the 90° brass elbows to pipe nipples.

Step 10: Running Hydraulic Tubing

Single Actuator System: Run hydraulic tubing between the actuators and cut to length. Secure tubing as needed. (See next page, Figure 8 for Single Actuator Systems.) **Dual Actuator Systems:** Run tubing from the Oildyne Hydraulic Power Units to the desired Brass Line-T location as shown. Secure as required. (See Figure 9 for Dual Actuator Systems.) Use tube bending clips at desired 90° bends in tubing to prevent kinking.

Step 11: Connecting Tubing to Actuators and Oildyne Hydraulic Power Units

(See Figure 7) Insert tubing through the nut with ferrule and into the 90° elbow.

Push until the tubing bottoms in the fitting. While continuing to bottom the tubing in the fitting, tighten nut “finger tight,” then one full turn . . . **NO MORE**. Do the same to connect the tubing to the Brass Line-Ts, and then from the Brass Line-Ts to the Oildyne Hydraulic Power Units.

Push tubing to bottom of fitting while tightening.
Tighten nut one full turn past finger tight - **NO MORE**.

Step 12: Installing Electronic Indicator Control

Wire control and electrical system per diagram and instructions in the next section for a XPT System with an EIC5000.

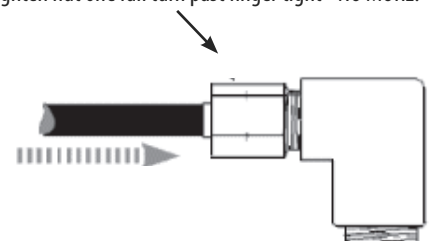

Figure 7

HYDRAULIC TUBING FOR SINGLE ACTUATOR SYSTEMS

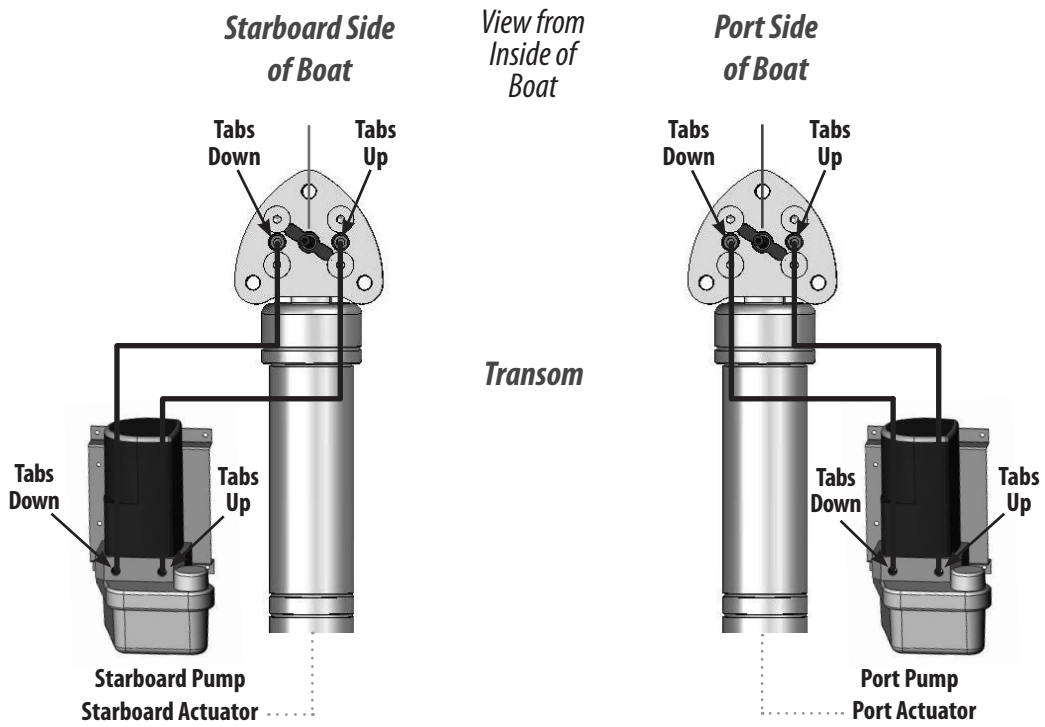

Figure 8

HYDRAULIC TUBING FOR DUAL ACTUATOR SYSTEMS

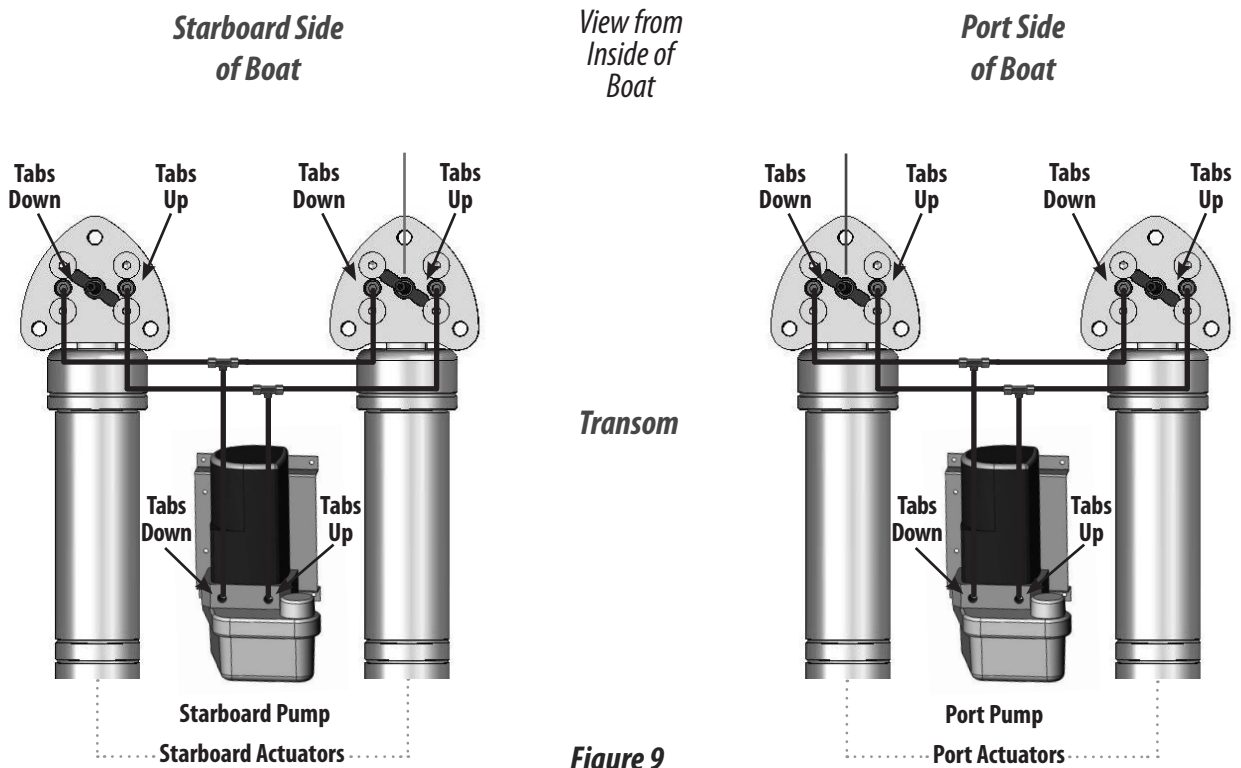

Figure 9

Electrical Connections and Parts List for Dual Acting, Single Station, Single Actuator XPT System with Electronic Indicator Control

For AutoTrim Pro control installation schematics, visit BennettTrimTabs.com/ATP

Item #	Description	Part #
1	EIC Display	EIC001
2	EIC Wire Harness (blue)	EIC201
3	EIC Relay Module*	EIC101
4	EIC Power Cables	Attached to EIC101
5	Port Dual Acting Relay Module*	RMPORT12DA
6	Starboard Dual Acting Relay Module*	RMSTBD12DA
7	EIC Dual Pump Cable (Y-Harness)	EICWH10101
8	Dual Acting Hydraulic Power Unit*	OILDYNE DAHPU

*Parts also available for 24 Volt systems.

Dual station systems also available.

Contact Info@BennettTrimTabs.com for parts and pricing.

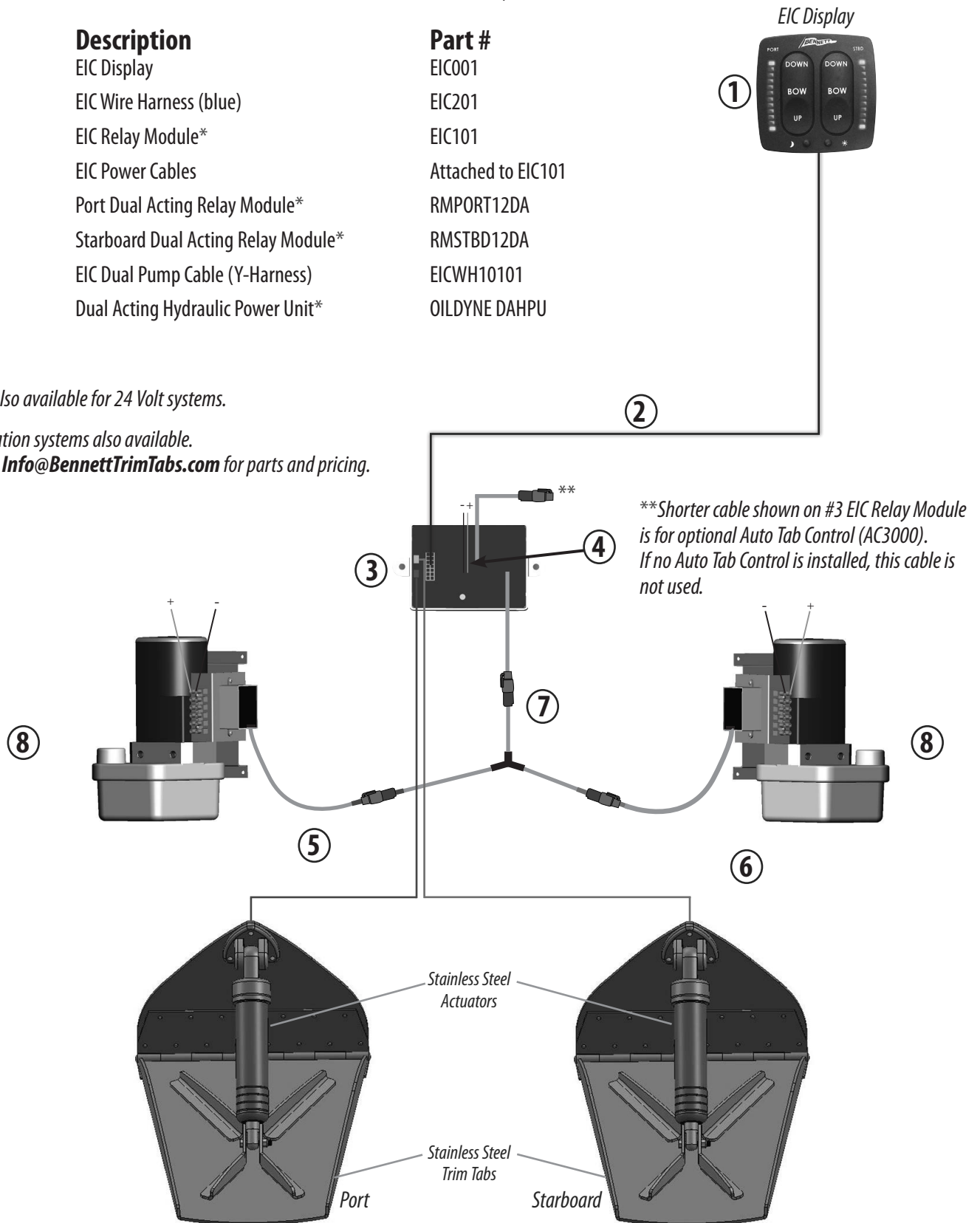

Installation Instructions for Electronic Indicator Control (EIC) Dual Station XPT System

IMPORTANT: MAKE ALL ELECTRICAL CONNECTIONS WITH POWER OFF

XPT Actuators with Sensor Wires should already be mounted per instructions on pages 4-5.

Step 1: Mounting the EIC Relay Module (#3 on System Schematic on Page 8)

- Mount the EIC Relay Module in a dry location centrally located between the two Dual Acting Hydraulic Power Units.

Step 2: Mounting the Port and Starboard Dual Acting Relay Modules

(#5 and #6 on System Schematic)

- Mount the Port Dual Acting Relay Module (Red Collar on the Connector) near the port Oildyne Hydraulic Power Unit.
- Mount the Starboard Dual Acting Relay Module (Green Collar on the Connector) near the starboard Oildyne Hydraulic Power Unit.
- Attach the black wires to battery ground. Attach the orange wires with inline fuse to the same battery positive power source. The orange wires will supply power to the Oildyne Hydraulic Power Units — make sure that the power source is rated for 20 amps (12V) or 10 amps (24V).

Step 3: Connecting the Y-Harness (#7 on System Schematic)

- Connect the “Y-Harness” to the longer of the two cables on the EIC Relay Module.
Note: The shorter cable coming out of the EIC Relay Module is for the optional Auto Tab Control (AC3000). If no Auto Tab Control is installed this cable is not used.
- Connect the Y-Harness plug with the Red Collar to the Port Dual Acting Relay Module plug (red to red).
- Connect Y-Harness plug with the Green Collar to the Starboard Dual Acting Relay Module plug (green to green).

Step 4: Connecting the Oildyne Hydraulic Power Unit (#8 on System Schematic) **Wire Harnesses to the Port and Starboard Dual Acting Relay Modules**

- Connect the Port Oildyne Hydraulic Power Unit Wire Harness to the Port Dual Acting Relay Module.
- Connect the Starboard Oildyne Hydraulic Power Unit Wire Harness to the Starboard Dual Acting Relay Module.

Step 5: Connecting the Oildyne Hydraulic Power Unit ground wire

- Run the black ground wire from the back of each Dual Acting Hydraulic Power Unit (#8 on System Schematic) to the vessel's 12V or 24V battery ground system.
- DO NOT connect to EIC Relay Module grounding stud. (See Figure 10 above)

Step 6: Connecting the Sensor Wires

- Plug the Grey sensor Wire into the Starboard Sensor Wire Connector (green collar) on the EIC Relay Module (#3 on System Schematic).
- Plug the Grey sensor Wire into the Port Sensor Wire Connector (red collar) on the EIC Relay Module (#3 on System Schematic).

Step 7: Mounting the EIC Display at the Helm (#1 on System Schematic)

Follow these instructions for both the Lower Helm and Upper Helm EIC Displays

- Using the enclosed paper EIC Display Template, mark the location for your EIC Display and locate the centers of the holes on the template.
- Use a 2" (51mm) hole-saw to cut the center hole and 3/16" (5mm) drill for the four mounting stud holes.

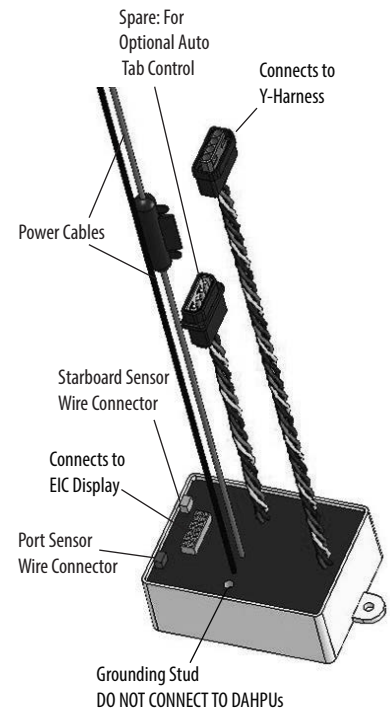

EIC Relay Module
Figure 10

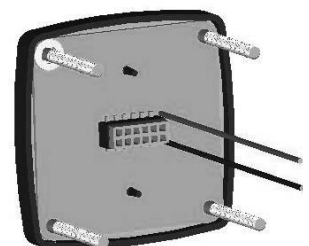

- Use a small bead of sealant around the perimeter of the display to seal.
- Using the 4 nylon thumb-nuts, secure the display. (Do not over-tighten.)

NOTE: IF YOU HAVE A DUAL STATION SYSTEM, GO TO STEP 9.

Step 8: Running the EIC Wire Harness (Part# EIC201, #2 on System Schematic)

- Plug the EIC Wire Harness (Blue Cable) into the back of the EIC Display and run to the location of the EIC Relay Module.
- Plug the Blue EIC Wire Harness into the EIC Relay Module.
- The cable must be properly strain relieved at both ends to support the weight of the blue cable. **GO TO STEP 14.**

FOR DUAL STATION SYSTEM ONLY

Step 9: Mounting the EIC Bridge Box

- Mount the EIC Bridge Box (Part# EIC701) within the length of the **thick gray** EIC Wire Harness (Part# EIC301) that will plug into the Lower Helm EIC Display.

Step 10: Connecting the EIC Wire Harness (Blue) to the EIC Bridge Box

- Plug the EIC Wire Harness (Part# EIC201) into the EIC Relay Module.
- Plug the other end of the Blue EIC Wire Harness into ANY of the three connectors on the Bridge Box.
- The cable must be properly strain relieved at both ends to support the weight of the blue cable at the Bridge Box.

Step 11: Connecting the Upper Helm EIC Display (secondary) to the EIC Bridge Box

- Plug the **thin gray** EIC Bridge Wire Harness (Part# EIC801) into the back of the Upper Helm EIC Display.
- Plug the EIC Bridge Wire Harness into ANY of the three connectors on the Bridge Box.
- The cable must be properly strain relieved at both ends to support the weight of the cable at the Bridge Box.

Step 12: Connecting the Lower Helm EIC Display (primary) to the EIC Bridge Box

- Plug the **thick gray** EIC Wire Harness (Part# EIC301) into the back of the Lower Helm EIC Display.
- Plug the EIC Wire Harness into the remaining connector on the Bridge Box.
- The cable must be properly strain relieved at both ends to support the weight of the cable at the Bridge Box.

Step 13: Cutting the Wiring for Upper Helm EIC Display (secondary)

- **DO NOT** connect the orange and purple wires at the Upper Helm EIC Display. Cut the orange and purple wires off the display.

GO TO STEP 14.

FOR BOTH DUAL AND SINGLE STATION SYSTEMS

Step 14: Connecting the Wiring for the Lower Helm EIC Display (primary)

- Connect the Purple wire containing the inline 1.5 amp fuse to the ignition switch or any 12 or 24 volt circuit that turns on with the ignition. **This wire is used to initiate Auto Tab Retraction when the ignition is switched to the off position.**
- Connect the Orange wire containing the inline 1.5 amp fuse to a source that supplies power to the boat's electronics and/or gauges. **This wire senses the power and shuts off the display when the helm power is shut off.**

Step 15: Connecting the Power and Ground on the EIC Power Cables (#4 on System Schematic) **to the EIC Relay Module**

- Attach the black wire to battery ground. Attach the orange wire with inline fuse to the same battery positive power source.

Calibration and Operation

Once installation of the XPT System is complete, use the EIC to bleed the system by holding down the “BOW DOWN” position for 15 seconds, then “BOW UP” for 15-20 seconds. Repeat 3 times. This will purge air from the system. Then place both tabs in the “full down” position and check all hydraulic connections for leaks. Bring the tabs to the **full UP** position and check the fluid level. Add ATF if necessary. Also check for leaks in the “UP” position.

Calibration — **NOTE: Calibration must be done at the Lower Helm EIC Display**

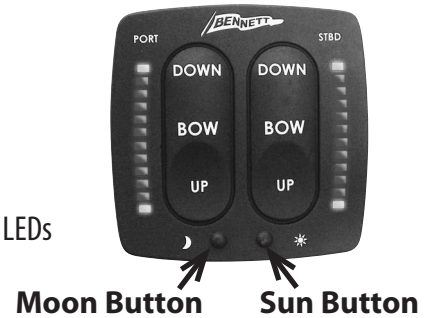

1. The port and starboard red LEDs will flash alternately, indicating that the system is not calibrated.
2. Press and hold the “sun” and “moon” buttons on the Lower Helm EIC Display simultaneously for approximately 3 seconds. Both the port and starboard **lower** yellow LEDs will begin to flash. Release the “sun” and “moon” buttons.
3. Using the Lower Helm EIC Display, run both trim tabs to the full down position (BOW DOWN on the control). **Make sure the tabs go all the way DOWN by holding the buttons**

for at least 15 seconds. (Holding the buttons after the tabs are down will not harm the system).

4. A few seconds after the tabs are all the way down, the port and starboard **upper** yellow LEDs will begin flashing. Again, using the Lower Helm EIC Display, run both tabs to the full up position (BOW UP on the control). **Make sure the tabs come all the way UP by holding the buttons for at least 15 seconds.**
5. The upper and lower yellow LEDs will then light up solidly, indicating that the EIC is calibrated and ready to operate. If you wish to recalibrate the EIC at any time, simply bring the tabs to the full up position, press and hold the “sun” and “moon” buttons down and repeat the calibration instructions.

Operation

The intensity of the display LEDs may be adjusted by pressing the “sun” button to brighten and the “moon” button to dim the display.

EIC Display Diagnostic Information

Port and starboard red LEDs alternately flash: EIC requires calibration. Refer to calibration information above.

Upper yellow LED flashes on port or starboard side: Indicates the EIC Display is not receiving a sensor signal. If the port upper yellow LED flashes the fault is in the port sensor or wires. A flashing yellow LED on the starboard side would indicate a fault on the starboard sensor or wires. Switching the sensor connections on the EIC Relay Module will confirm the diagnostic code if the flashing LEDs switch sides. If the problem switched sides, check the suspected faulty actuator with an Ohm meter at the EIC sensor cable plug. The reading should be in the 220-260 Ohm range. If the sensor readings are good, check for faulty connections (corrosion or broken wires).

Dual Acting XPT System Troubleshooting Guide

Before proceeding with the tests below, verify that each orange power wire is connected to a live positive power source, and that the fuses are not blown. Make sure that each black wire has a good connection to ground.** After this is complete, conduct the tests below.*

STEP 1A — Troubleshooting for Port Oildyne Hydraulic Power Unit and Port Dual Acting Relay Module

Unplug the port Dual Acting Hydraulic Power Unit from the Port Dual Acting Relay Module (RMPORTDA). Using a hot lead, directly power the Oildyne Hydraulic Power Unit plug as shown below:

Operation	Reaction
Touch positive to Red and Blue Simultaneously	Port trim tab up
Touch positive to Green and Blue Simultaneously	Port trim tab down

If the port trim tab does not move when the Oildyne is powered direct, then the port Oildyne or port actuator(s) are faulty. Contact Bennett Marine.

If the port trim tab still moves, plug the Oildyne Hydraulic Power Unit back into the Port Dual Acting Relay Module (RMPORTDA). Unplug the RMPORTDA from the EIC Dual Pump Cable (Y-Harness). Take the RMPORTDA and using a hot lead directly power the three-color wire pigtail featuring a red heat shrink collar as shown below:

Operation	Reaction
Touch positive to Red and Blue Simultaneously	Port trim tab down
Touch positive to Red and Yellow Simultaneously	Port trim tab up

If the port trim tab does not move when powered through the Port Dual Acting Relay Module, then the RMPORTDA is faulty.

STEP 1B — Troubleshooting for Starboard Oildyne Hydraulic Power Unit and Starboard Dual Acting Relay Module

Unplug the starboard Dual Acting Hydraulic Power Unit from the Starboard Dual Acting Relay Module (RMSTBDDA). Using a hot lead, directly power the Oildyne Hydraulic Power Unit plug as shown below:

Operation	Reaction
Touch positive to Red and Blue Simultaneously	Starboard trim tab up
Touch positive to Green and Blue Simultaneously	Starboard trim tab down

If the starboard trim tab does not move when Oildyne Hydraulic Power Unit is powered direct, then the starboard Oildyne Hydraulic Power Unit or starboard actuator(s) are faulty. Contact Bennett Marine for assistance.

If the starboard trim tab still moves, plug the Oildyne Hydraulic Power Unit back into the Starboard Dual Acting Relay Module (RMSTBDDA). Unplug the RMSTBDDA from the EIC Dual Pump Cable (Y-Harness). Take the RMSTBDDA and using a hot lead directly power the three-color wire pigtail featuring a green heat shrink collar as shown below:

Operation	Reaction
Touch positive to Green and Blue Simultaneously	Starboard trim tab down
Touch positive to Green and Yellow Simultaneously	Starboard trim tab up

If the starboard trim tab does not move when powered through the Starboard Dual Acting Relay Module, then the RMSTBDDA is faulty.

* This system could contain up to five (5) fuses — three (3) 1.5 amp, with two (2) 10 amp (24V) or two (2) 20 amp (12V). The boat builder could have replaced these fuses with breakers, or used breakers and inline fuses.

** There are five (5) ground (black wires) — two (2) Oildyne Hydraulic Power Units, two (2) Dual Acting Relay Modules and one (1) EIC Relay Module.

STEP 2

Before proceeding with the tests below, verify that each orange power wire is connected to a live positive power source and that the fuses* are not blown. Make sure that each black wire has a good connection to ground.** After this is complete, conduct the tests below.

If the trim tab(s) is still operational after conducting the tests in Step 1, then either the Y-Harness or EIC Relay Module is at fault. Perform the test below by removing the EIC Dual Pump Cable (Y-Harness) from the EIC Relay Module. Using a hot lead, directly power the end of the Y-Harness just removed from the EIC Relay Module (four wires in the plug) as shown below:

Operation	Reaction
Touch positive to Red and Blue Simultaneously	Port trim tab down
Touch positive to Red and Yellow Simultaneously	Port trim tab up
Touch positive to Green and Blue Simultaneously	Starboard trim tab down
Touch positive to Green and Yellow Simultaneously	Starboard trim tab up
Touch positive to Red, Green and Blue Simultaneously	Both trim tabs down
Touch positive to Red, Green, and Yellow Simultaneously	Both trim tabs up

If the trim tab(s) is still not operational when powered through the Y-Harness, then the Y-Harness is faulty.

If both trim tabs operate as they should after conducting the above test, then the EIC Relay Module may be faulty. Conduct the following test by directly powering the shorter, unused cable on the EIC Relay Module:

Operation	Reaction
Touch positive to Red and Blue Simultaneously	Port trim tab down
Touch positive to Red and Yellow Simultaneously	Port trim tab up
Touch positive to Green and Blue Simultaneously	Starboard trim tab down
Touch positive to Green and Yellow Simultaneously	Starboard trim tab up
Touch positive to Red, Green and Blue Simultaneously	Both trim tabs down
Touch positive to Red, Green, and Yellow Simultaneously	Both trim tabs up

If the trim tab(s) is still not operational when powered through the EIC Relay Module, then the EIC Relay Module is faulty.

If both trim tabs operate properly when the above test is conducted, then either the EIC Display or the EIC Wire Harness is at fault. Ensure that both ends of the EIC Wire Harness are seated firmly in the plugs, and that the EIC Display's orange wire has proper voltage.

* This system could contain up to five (5) fuses — three (3) 1.5 amp, with two (2) 10 amp (24V) or two (2) 20 amp (12V). The boat builder could have replaced these fuses with breakers, or used breakers and inline fuses.

** There are five (5) ground (black wires) — two (2) Oildyne Hydraulic Power Units, two (2) Dual Acting Relay Modules and one (1) EIC Relay Module.

XPT System Options

Mounting Hole Variations

The unique design of the XPT actuator lower hinge allows you to easily make adjustments to the installation angle and lift without drilling new holes in the transom.

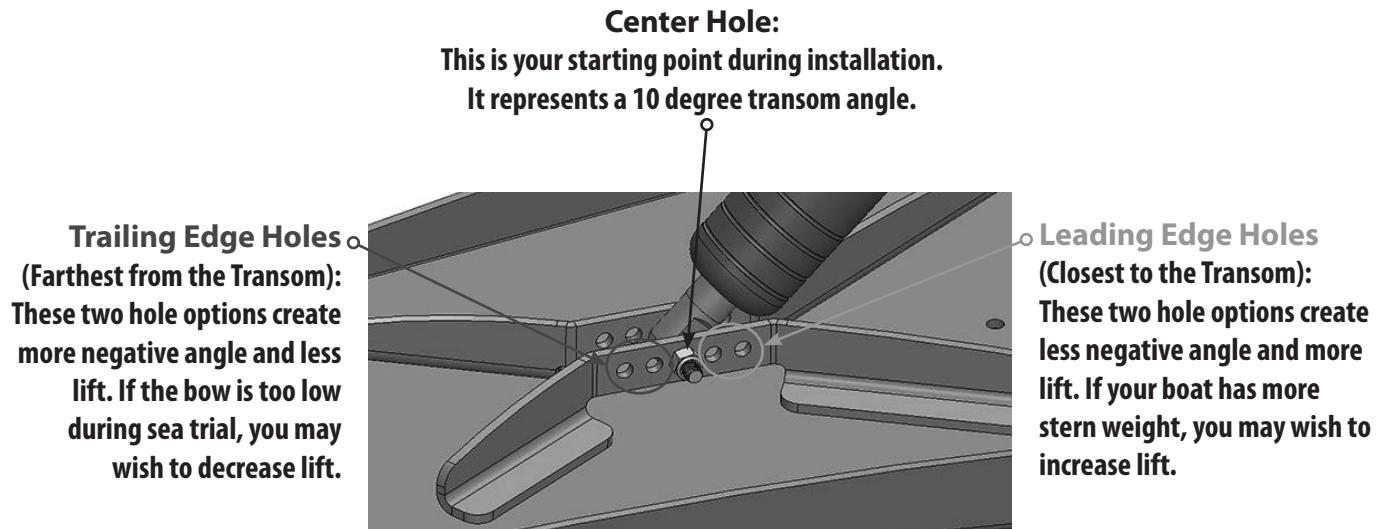

Stainless Steel Hydraulic Lines



**Available upon request.
Call +1.954.427.1400 or email
Info@BennettTrimTabs.com for a
customized quotation.**

More exceptional Bennett Marine products...

Premier Line Stainless Steel XPT, BXT, & SST Trim Tab Kits



When only the best will do, Bennett's exceptional Premier Line Trim Tab systems are your only option. With superior design and engineering, Premier systems are built to the highest standards of durability, uniting form and function by employing the highest quality materials and the power of hydraulics.

Features Include:

- Designed for luxury motor yachts, military and government vessels, high-performance sport fishing boats, and commercial vessels
- No external hydraulic lines or cables exposed to extreme marine environments
- All stainless steel construction assures highest resistance to corrosion from dissimilar metals
- Powerful dual acting hydraulics provide precision control of the stainless steel actuators
- Multiple actuator mounting points provide adjustability
- Backed by Bennett's legendary customer service

Kits Include:

- (1) Helm control (EIC or AutoTrim Pro)
- (2) Compact dual acting hydraulic power units
- (2-4) Stainless steel hydraulic actuators
- (2) Heavy duty 7-gauge trim planes
- Hydraulic tubing and hardware

Complete Kits with EIC



PN#	SPAN/CHORD	*ACTUATORS
XPT1218EIC	12"x18"	2
XPT1520EIC	15"x20"	2
XPT1824EIC	18"x24"	2
BXTEIC	Custom	2
SSTEIC	Custom	2

*Actuators per tab

Complete Kits with AutoTrim Pro



PN#	SPAN/CHORD	*ACTUATORS
XPT1218ATP	12"x18"	2
XPT1520ATP	15"x20"	2
XPT1824ATP	18"x24"	2
BXTATP	Custom	2
SSTATP	Custom	2

*Actuators per tab

All-in-One Auto Trim Tab Control System



AutoTrim Pro is an all-in-one auto trim tab control system designed for boats of all sizes—packing a boatload of essential features into an easy-to-use, space-saving keypad. Reduce bow rise, improve visibility, correct listing—automatically.

PN#	DESCRIPTION
AP000A1HA	AutoTrim Pro for Hydraulic Systems
AP000A1BC	AutoTrim Pro for Electric Systems

Kits Include:

- (1) ATP helm display (ATPDISP)
- (1) ATP control unit (ATPHYDCTRL or ATPBOLTCTRL)
- (1) 25' extension cable (BHW4025)
- Required hardware



Features Include:

- Compatible with Bennett hydraulic or electric trim tab systems and most non-Bennett trim tab systems
- Auto trim tab control with favorite buttons
- Take manual control of your trim tabs at any time
- Trim tab position indication with adjustable L.E.D.s
- Auto tab retraction when ignition is powered off
- Customizable response time via wifi mobile app



Watch the video
BennettTrimTabs.com/ATP

Learn about the mobile app at
BennettTrimTabs.com/ATP



Bennett Marine XPT System Warranty

Bennett Marine warrants the equipment that is sold and supplied against any faulty manufacturing defects.

1) Warranty validity period:

a. The warranty period is twelve (12) months starting from the date of the first use by the original consumer. In the event that our systems are mounted or used on work or commercial boats the warranty period is six (6) months from the date of first use. The manufacturer has the right to require from the client proof of the date specified on the warranty request.

b. This period is neither extended nor interrupted through legal or amicable claims on the part of the client. At the end of this period, the warranty is terminated without further consideration.

c. The warranty will not be renewed following replacement or if the item is resold.

2) Conditions that make the warranty null and void:

a. The obligation of the warranty will not apply in case of negligence, faulty installation or maintenance, operator's responsibility, imprudence, non-observance of recommended operating instructions, incidents resulting from a cause of force majeure, or the use of automatic transmission fluid of insufficient quantity for this equipment.

b. The warranty is not valid where some of Bennett components are installed on a control system together with other manufacturers' products.

c. The warranty does not apply if the faulty equipment is not returned to Bennett Marine and if it has been previously disassembled, repaired, modified by either the user or by a third party.

d. The warranty does not cover failure due to the construction or choice of unsuitable materials by ordering the product in spite of prior advice or as standard guidelines, given by Bennett Marine.

3) Conditions of equipment failure

a. In case of equipment failure within its warranty period, Bennett Marine must be contacted to authorize any replacement parts. The client must allow the technician to be able to ascertain the defects and to perform corrective actions. After receiving proper notification of the equipment defect, the technician shall correct this fault as soon as reasonably possible, reserving the right, if applicable, to modify all or part of the equipment in order to fulfill the obligations.

b. The replacement of the defective components under warranty condition is left to Bennett Marine's judgment.

c. The defective products must be sent pre-paid together with a copy of the invoice or vessel's bill of sale.

d. In case the repairs are not under warranty as specified in the condition paragraph 2, the owner agrees to pay the boat repair yard for said work, labor and materials. Verbal price quotes by personnel are rough estimates and are not binding; all orders must be in writing and signed by the owner and the manufacturer or distributor.

e. During the warranty period, the dismantling, repairing and reassembly of the faulty items are the responsibility of Bennett Marine. The shipping costs for repaired or replaced products, as well as for hauling and labor costs shall be paid by the client.

f. All work performed on vessels can only occur with Owner's specific instructions. However, in emergency cases, Bennett Marine reserves the right to repair Owner's vessel if in the opinion of Bennett Marine or our distributor an emergency arises making such action necessary in the protection of the vessel. Owner agrees to pay for these emergency repairs at the prevailing rates.

g. Bennett Marine reserves all rights against the vessel and personally against the owner for payment of all charges in full.

h. Bennett Marine shall not be responsible for any damage to said vessel or damage to or loss of any articles or personal property, gear, or any other appurtenances left aboard the vessel.

i. Bennett Marine does not provide insurance for the vessel; the insurance liability coverage is for Bennett Marine only. Owner agrees that he will provide his own insurance for his vessel and will keep coverage in effect for the time period the vessel is being repaired.

4) General warranty terms

a. The obligation of the warranty only applies if the defect appeared under normal operating conditions stipulated for this type of vessel, or indicated by the statement of purpose or intended use to the manufacturer in writing.

b. The components replaced under warranty must be returned to Bennett Marine as they are no longer the owner's property.

c. Bennett Marine reserves the right to change its models or parts without any obligation to make the same alterations to any products previously manufactured.

d. The manufacturer will not be responsible for damage resulting from the client's non-compliance with any of the obligations defined above.

e. No claim may be made for compensation such as personal injury, damage to goods other than those concerned in this document, operating losses, commercial damage or loss of earnings.

