

Installation: Refer to figure-1. Install the seacock in accordance with ABYC H-27 onto a backing block of suitable material for wet bilge areas. The backing block serves to further spread the load, but not directly on the hull section through which the thru-hull fitting penetrates. Some installers prefer bolting through the hull and backing block, while others will bond the backing block permanently to the hull, and then bolt into the backing block, but not all the way through the hull. Either installation is acceptable. Depending on the combined backing block + hull thickness, the thru-hull fitting length may need to be reduced so it does not bottom out inside the seacock before proper compression is achieved.

Reversing Handle Rotation: GROCO FBV seacocks includes the patented user-selectable handle rotation feature. If seacock location does not allow unobstructed handle operation, you may change the rotation direction by relocating the set-screw beneath the handle. The set-screw may be removed all-together if 180-degree handle rotation is desired.

Square Handle Hole: GROCO FBV seacock handle has a square hole that will accept a standard ratchet extension. Use this feature to break loose a stuck valve or to reach the handle in an inaccessible location. Exercise caution when operating the valve with a ratchet handle attached as the added length provides a mechanical advantage that could damage the valve handle.

Bonding: The seacock base has a bonding screw. Use at least 14ga marine grade stranded copper wire to connect the seacock to the vessel bonding system. Bonding may be made in series with other non-motorized equipment such as strainers. **WARNING: DO NOT** bond motorized equipment such as air conditioner pumps in series with the seacock. Motorized equipment must have a separate connection to the vessel AC or to the DC grounding bus, in accordance with ABYC E-11, Figure-18.

Operation: The valve is closed when the handle is horizontal (perpendicular to the thru-hull fitting) and is open when vertical (parallel to the thru-hull fitting).

Winterization: Freezing may damage the seacock and connected plumbing if left filled with water. In freezing conditions, close the seacock and drain the water from the valve by removing the drain plug(s). Replace and tighten the drain plug(s) after draining.



Connections: GROCO offers a complete line of straight, 45-degree and 90-degree cast bronze pipe/hose fittings in full flow (FF or FFC) or standard flow (PTH or PTHC) models to complete your installation. Use TFE thread tape on threaded connections; double clamp hose connections.

Maintenance: No regular maintenance is required. It is recommended that the valve be operated at least monthly to assure free movement and to prevent the build-up of nuisance marine growth.

Lubrication: FBV seacocks are fitted with one drain plug and one zerk fitting. The zerk serves as an additional drain plug but also provides for the injection of GROCO U-LUBE lubricant into the space between the ball and the valve body. U-LUBE (available in 3-oz or 14-oz tubes) is specially formulated for ball valves to lubricate wear parts and to discourage the accumulation of nuisance marine growth.

IMPORTANT - Inject U-LUBE only with the valve in the open position. Remove the drain plug to let the air or water out, and so you can visually determine when the valve is full of U-LUBE grease. Inject U-LUBE with a standard grease gun through the zerk fitting. When U-LUBE appears at the drain plug port, stop pumping. Replace and securely tighten the drain plug.

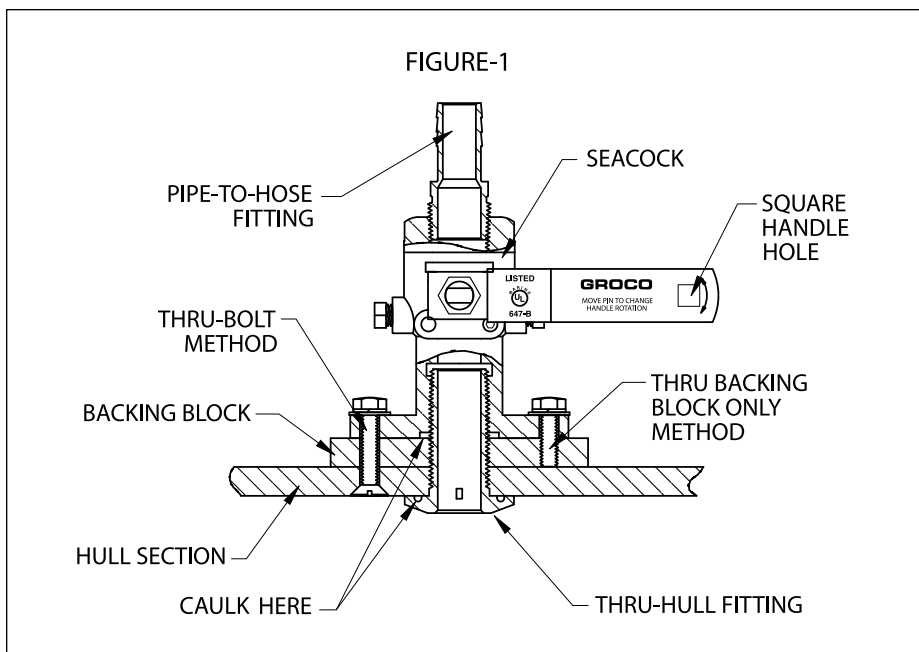

© 1999 GROSS MECHANICAL LABORATORIES, INC. ALL RIGHTS RESERVED.